

BRx Series

BR-AS... Bracket Assemblies for use with SQM... Actuators

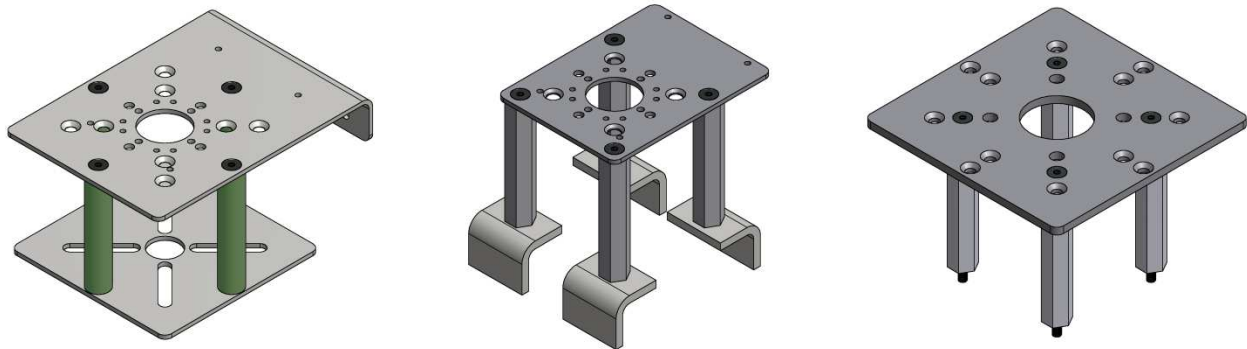

Description

BRx... series bracket assemblies installed with Cxx... series couplings precisely mount a Siemens SQM... actuator to a valve or damper.

Features

- Engineered for precise shaft alignment
- Rigid and robust design
- Multiple mounting options for simple installation
- High-temperature bracket assemblies available
- Standoff options accommodate a variety of shaft lengths

Application

BRx... series bracket assemblies assist installation of any Siemens SQM... actuator to a variety of valves or dampers. The modular bracket design provides options to easily mount SQM... actuators. BRx... series bracket assemblies are engineered for use with Cxx... series couplings.

Product Part Numbers

For bracket assembly part number identification only. Not all possible part number combinations are available. See Tables 1, 2, and 3 on the following pages for available bracket assembly part number combinations.

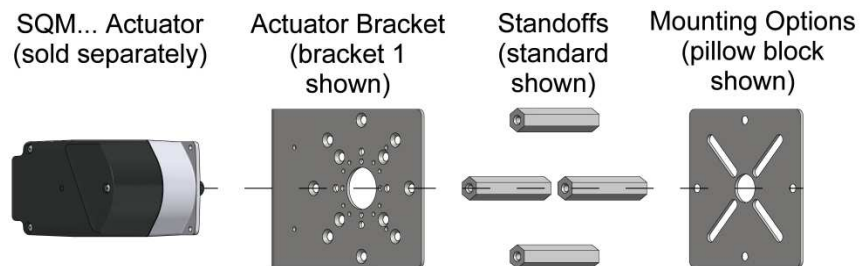
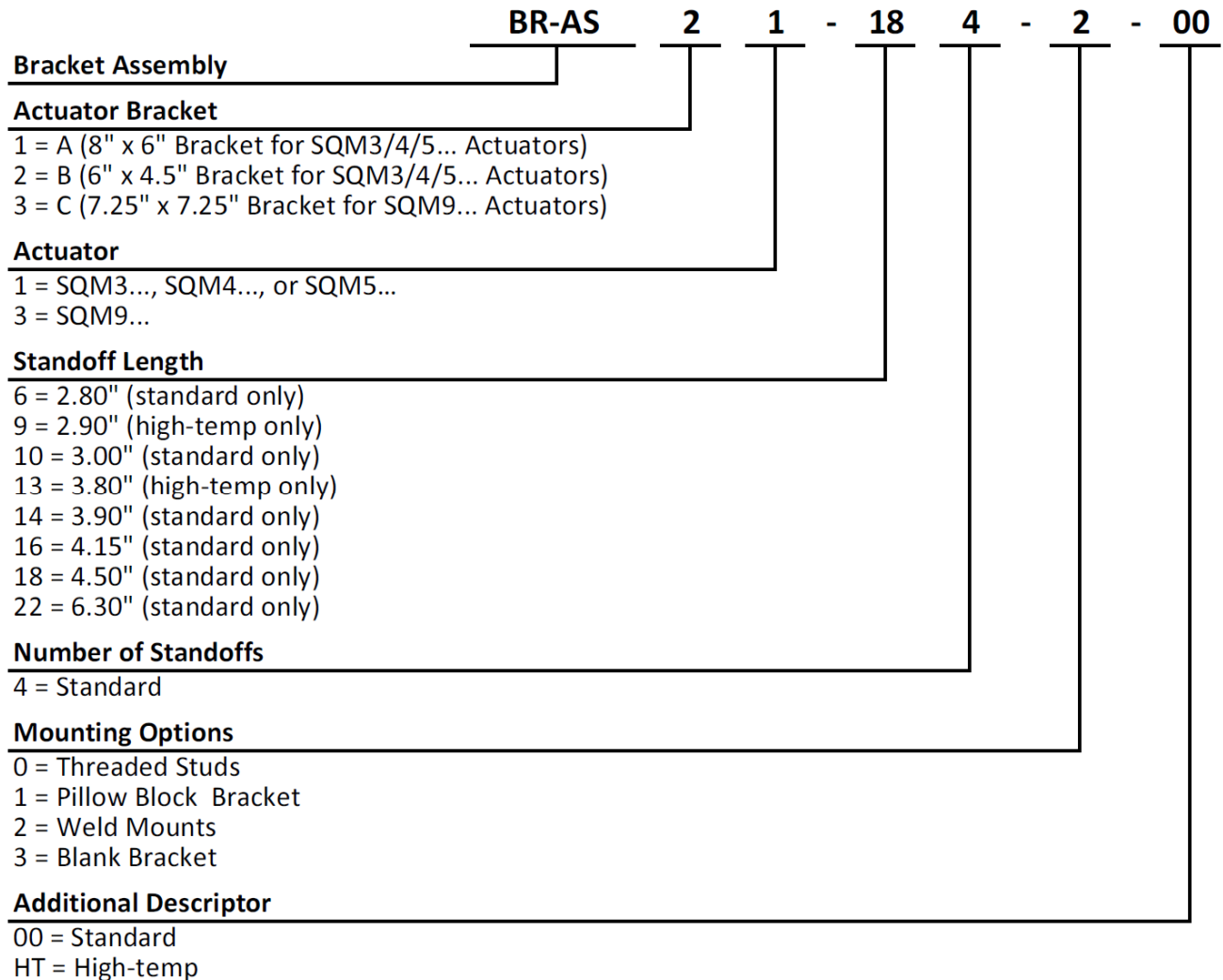

Figure 1: Components of Bracket Assemblies

Product Part Numbers (continued)

Bracket assembly part numbers are listed in Tables 1, 2, and 3. For help selecting the proper part number, see pages 5-7.

Note: All necessary mounting hardware is included with the bracket assembly.

Table 1: Bracket Assemblies Using Actuator Bracket 1

Mounting Type	Standoff Length	Assembly Part Number
Pillow Block Bracket	2.80"	BR-AS11-64-1-00
	2.90"	BR-AS11-94-1-HT
	3.00"	BR-AS11-104-1-00
	3.80"	BR-AS11-134-1-HT
	3.90"	BR-AS11-144-1-00
	4.15"	BR-AS11-164-1-00
	4.50"	BR-AS11-184-1-00
	6.30"	BR-AS11-224-1-00
Weld Mounts	2.80"	BR-AS11-64-2-00
	2.90"	BR-AS11-94-2-HT
	3.00"	BR-AS11-104-2-00
	3.80"	BR-AS11-134-2-HT
	3.90"	BR-AS11-144-2-00
	4.15"	BR-AS11-164-2-00
	4.50"	BR-AS11-184-2-00
	6.30"	BR-AS11-224-2-00
Blank Bracket	2.80"	BR-AS11-64-3-00
	2.90"	BR-AS11-94-3-HT
	3.00"	BR-AS11-104-3-00
	3.80"	BR-AS11-134-3-HT
	3.90"	BR-AS11-144-3-00
	4.15"	BR-AS11-164-3-00
	4.50"	BR-AS11-184-3-00
	6.30"	BR-AS11-224-3-00
Threaded Studs	2.80"	BR-AS11-64-0-00
	2.90"	BR-AS11-94-0-HT
	3.00"	BR-AS11-104-0-00
	3.80"	BR-AS11-134-0-HT
	3.90"	BR-AS11-144-0-00
	4.15"	BR-AS11-164-0-00
	4.50"	BR-AS11-184-0-00
	6.30"	BR-AS11-224-0-00

Product Part Numbers (continued)

Table 2: Bracket Assemblies Using Actuator Bracket 2

Mounting Type	Standoff Length	Assembly Part Number
Weld Mounts	2.80"	BR-AS21-64-2-00
	2.90"	BR-AS21-94-2-HT
	3.00"	BR-AS21-104-2-00
	3.80"	BR-AS21-134-2-HT
	3.90"	BR-AS21-144-2-00
	4.15"	BR-AS21-164-2-00
	4.50"	BR-AS21-184-2-00
Blank Bracket	6.30"	BR-AS21-224-2-00
	2.80"	BR-AS21-64-3-00
	2.90"	BR-AS21-94-3-HT
	3.00"	BR-AS21-104-3-00
	3.80"	BR-AS21-134-3-HT
	3.90"	BR-AS21-144-3-00
	4.15"	BR-AS21-164-3-00
Threaded Studs	4.50"	BR-AS21-184-3-00
	6.30"	BR-AS21-224-3-00
	2.80"	BR-AS21-64-0-00
	2.90"	BR-AS21-94-0-HT
	3.00"	BR-AS21-104-0-00
	3.80"	BR-AS21-134-0-HT
	3.90"	BR-AS21-144-0-00
4.15"	BR-AS21-164-0-00	
4.50"	BR-AS21-184-0-00	
6.30"	BR-AS21-224-0-00	

Product Part Numbers (continued)
Table 3: Bracket Assemblies Using Actuator Bracket 3

Mounting Type	Standoff Length	Assembly Part Number
Pillow Block Bracket	3.80"	BR-AS33-134-1-HT
	3.90"	BR-AS33-144-1-00
	4.15"	BR-AS33-164-1-00
	4.50"	BR-AS33-184-1-00
	6.30"	BR-AS33-224-1-00
Weld Mounts	3.80"	BR-AS33-134-2-HT
	3.90"	BR-AS33-144-2-00
	4.15"	BR-AS33-164-2-00
	4.50"	BR-AS33-184-2-00
	6.30"	BR-AS33-224-2-00
Blank Bracket	3.80"	BR-AS33-134-3-HT
	3.90"	BR-AS33-144-3-00
	4.15"	BR-AS33-164-3-00
	4.50"	BR-AS33-184-3-00
	6.30"	BR-AS33-224-3-00
Threaded Studs	3.80"	BR-AS33-134-0-HT
	3.90"	BR-AS33-144-0-00
	4.15"	BR-AS33-164-0-00
	4.50"	BR-AS33-184-0-00
	6.30"	BR-AS33-224-0-00

Product Part Numbers (continued)

The following three steps are to be used as a guide for choosing a proper bracket assembly part number. None of the components listed below may be ordered separately. See pages 11-15 for dimensions of each bracket component.

1. Select a Mounting Option

Pillow Block Bracket



This bracket is used when mounting Siemens SQM... actuators to an air damper that uses pillow block bearings to support the shafts. The bracket sits above the pillow block with mounting screws going through the diagonal slots in the bracket.

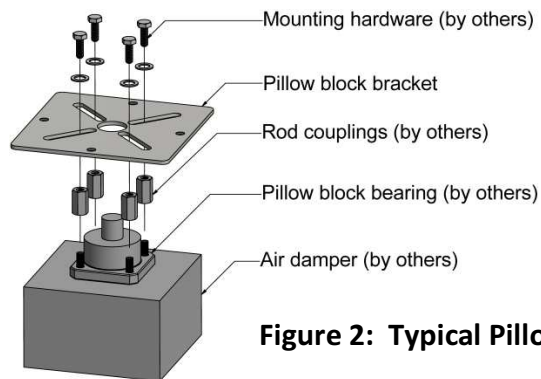

Figure 2: Typical Pillow Block Mounting

Weld Mounts



Weld mount brackets provide an easy and secure installation option. A standoff is bolted to the bracket which is non-galvanized and can be easily welded for mounting. Four weld mounts are included in a bracket assembly, one for each standoff.

Blank Bracket



The blank bracket kit allows custom holes to be drilled and tapped. Four holes around the outside of the bracket are provided to mount standoffs on the 5.00" bolt circle.

Threaded Studs



Use 1/4"-20 threaded studs to mount the bracket assembly directly to a valve or damper. 1.25" long threaded studs are provided with each assembly.

Product Part Numbers (continued)

2. Select an Actuator Bracket

Bracket 1



Actuator mounting bracket 1 is approximately 8.0" x 6.0" in size and may be used with SQM3..., SQM4..., or SQM5... actuators. There is a 90° bend at the end of the bracket for the option of securing the bracket assembly from the side.

Bracket 2



Actuator mounting bracket 2 is approximately 6.0" x 4.5" in size and may be used with SQM3..., SQM4..., or SQM5... actuators.

Bracket 3

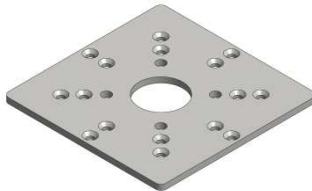

Actuator mounting bracket 3 is approximately 7.25" x 7.25" in size and is to be used with SQM9... actuators.

3. Select a Standoff Length

Standoffs



Each bracket assembly comes with four standoffs. Standoffs are available in different lengths to accommodate a variety of valve or damper shafts. Two high-temperature standoff lengths are also available. The "Standoff Selection Guide" on the following page determines the standoff length required.

Product Part Numbers (continued)

Standoff Selection Guide

Standoffs are available in the following lengths:

Standard	High-temp
2.80", 3.00", 3.90", 4.15", 4.50", 6.30"	2.90", 3.80"

Use the guide below to find the minimum and maximum standoff lengths allowed. These are determined by the minimum and maximum shaft engagement in the coupling. Then, select a size from the list above that falls between the calculated minimum and maximum lengths. If more than one length of standoff is suitable, select the one that is closest to the average of the minimum and maximum lengths. If none of the standoff lengths are suitable, contact SCC Inc. for more information.

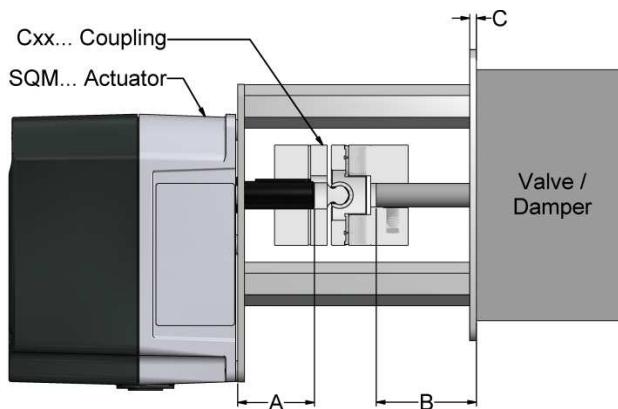

Dimension A: Actuator Shaft Length
 For SQM3x.xxx... actuators: A = 0.99"
 For SQM4x.xx5... actuators: A = 0.99"
 For SQM4x.xx7... actuators: A = 1.54"
 For SQM5x.xx7... actuators: A = 1.71"
 For SQM9x.xxx... actuators: A = 1.77"

Dimension B: Valve / Damper Shaft Length
 Measure the shaft length on the valve or damper

Dimension C: Thickness of Valve / Damper Bracket
 Mounting with pillow block bracket: C = 0.135"
 Mounting with weld mounts: C = 1.50"
 Mounting with blank bracket: C = 0.135"
 Mounting with threaded studs: C = 0"

D: Correction
 For SQM3x.xxx... actuators: D = 0.27
 For SQM4x.xx5... actuators: D = 0.27
 For SQM4x.xx7... actuators: D = 0
 For SQM5x.xx7... actuators: D = 0
 For SQM9x.xxx... actuators: D = 0

Figure 3: Standoff Selection Guide

For bracket assemblies being combined with a CC... or CD... coupling:

$$\text{Minimum allowable standoff length} = A + B + D + 0.44 - C$$

$$\text{Maximum allowable standoff length} = A + B + 1.08 - C$$

For bracket assemblies being combined with a CF... or CH... coupling:

$$\text{Minimum allowable standoff length} = A + B + D + 0.74 - C$$

$$\text{Maximum allowable standoff length} = A + B + 1.30 - C$$

For bracket assemblies being combined with a CJ... or CK... coupling:

$$\text{Minimum allowable standoff length} = A + B + 0.66 - C$$

$$\text{Maximum allowable standoff length} = A + B + 1.61 - C$$

Accessories

Cxx... Couplings



Cxx... series couplings precisely connect Siemens SQM... actuators to a wide variety of valves and dampers. Cxx... series couplings are highly recommended with any BRx... series bracket assembly. See Document No. CPBK-1000 for more information on Cxx couplings.

VA... Valve Actuator Assemblies

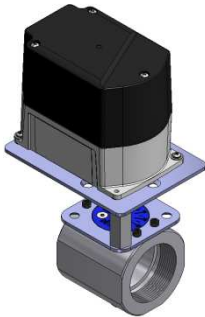

Pre-built valve actuator assemblies can be ordered to ensure proper shaft alignment and engagement. Assemblies include the valve, actuator, coupling, and bracket which are configured, tested, and shipped as an assembly. Contact SCC Inc. for more information.

Specifications

Physical characteristics	Flat brackets	Zinc-Plated Steel
	Weld mounts	Low Alloy Steel (non-galvanized)
	Standoffs (standard)	Aluminum
	Standoffs (high-temp)	Phenolic G-10/FR-4
	Fasteners	Alloy Steel

Operating environment	Ambient temperature	-4 to 140°F [-20 to 60°C]
	Mounting surface temperature	-40 to 150°F [-40 to 66°C] with standard standoffs
		*With high-temp standoffs, a 300°F mounting surface temperature will cause an actuator temperature of 20°F over ambient. Contact SCC Inc. for more information.

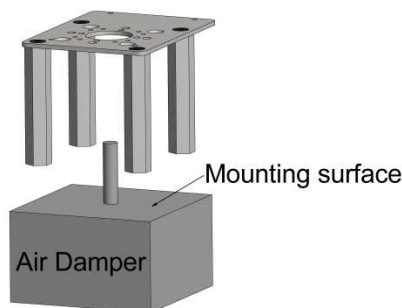

Installation

- Bracket assemblies can be indexed in 45° or 90° increments relative to the valve or damper depending on the actuator bracket (see below).

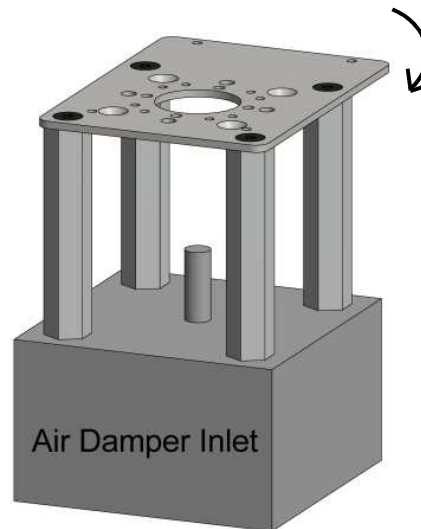

Figure 4: Bracket Assembly Indexing

- All bracket assemblies include the fasteners to mount an SQM... actuator to the actuator bracket. Some bracket assemblies include additional hardware that will not be used. Based on the SQM... actuator being mounted, use Table 4 to determine which mounting screws are necessary. Table 4 also details the manner by which the screws mount the actuator to the actuator bracket.

Table 4: Actuator Mounting Screws

Actuator	Quantity of Screws	Type of Screws	Mounting Method
SQM3...	2	#14 thread-forming	Self-tap into actuator
SQM4...	4	M5 thread-forming	Self-tap into bracket
SQM5...	3	M5 thread-forming	Thread into actuator
SQM9...	4	M10 hex head	Thread into actuator

- Use medium strength blue Loctite (#242) on all fasteners that are not accompanied by lock washers.
- If using a CF... or CH... coupling, the standoffs must be mounted on the 5.00" bolt circle. If standoffs are mounted on the 3.25" bolt circle, the set screws in the coupling will interfere with the standoffs. Consult SCC if the 3.25" bolt circle must be used with a CF... or CH... coupling.

Installation (continued)

Installation with pillow block bracket:

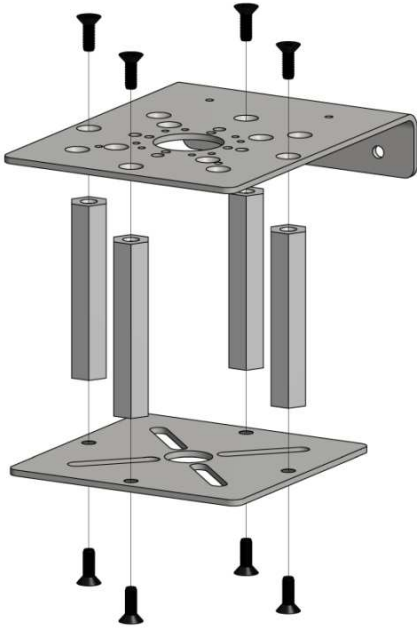

Installation with weld mounts:

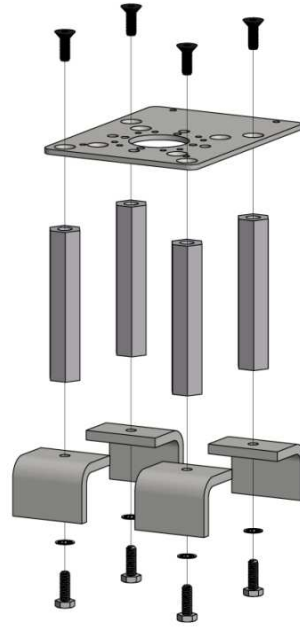

Installation with blank bracket

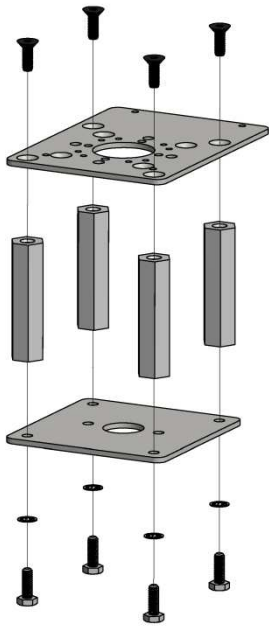

Installation with threaded studs

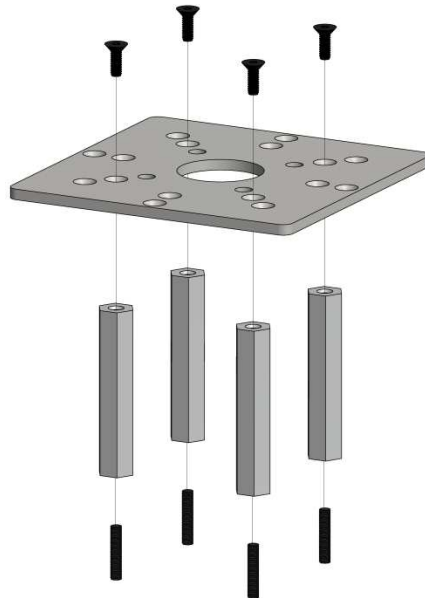

Dimensions

Dimensions in inches; millimeters in brackets

Actuator Bracket 1

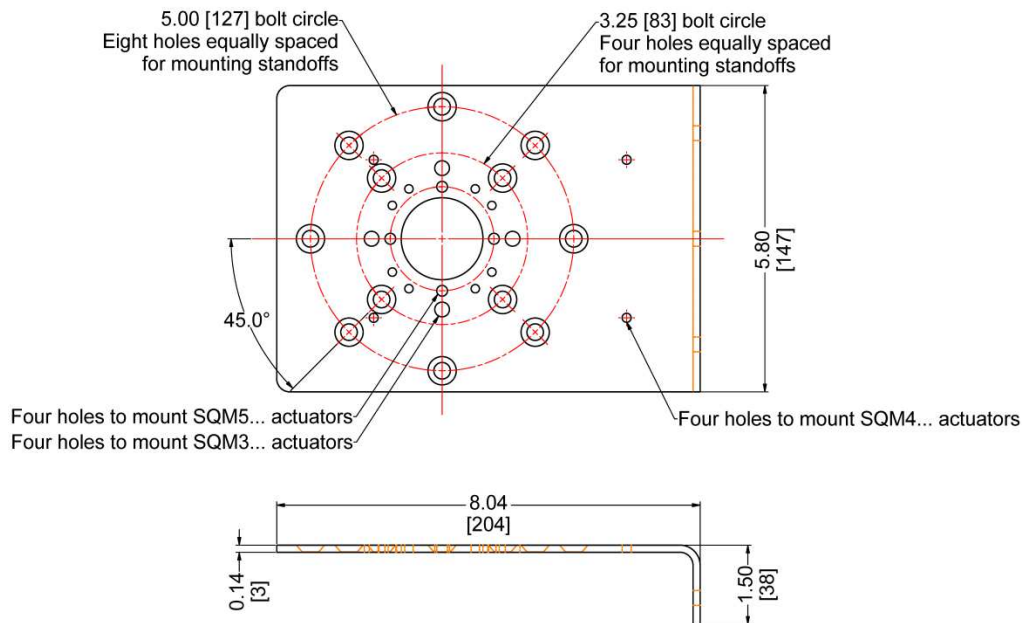

Actuator Bracket 2

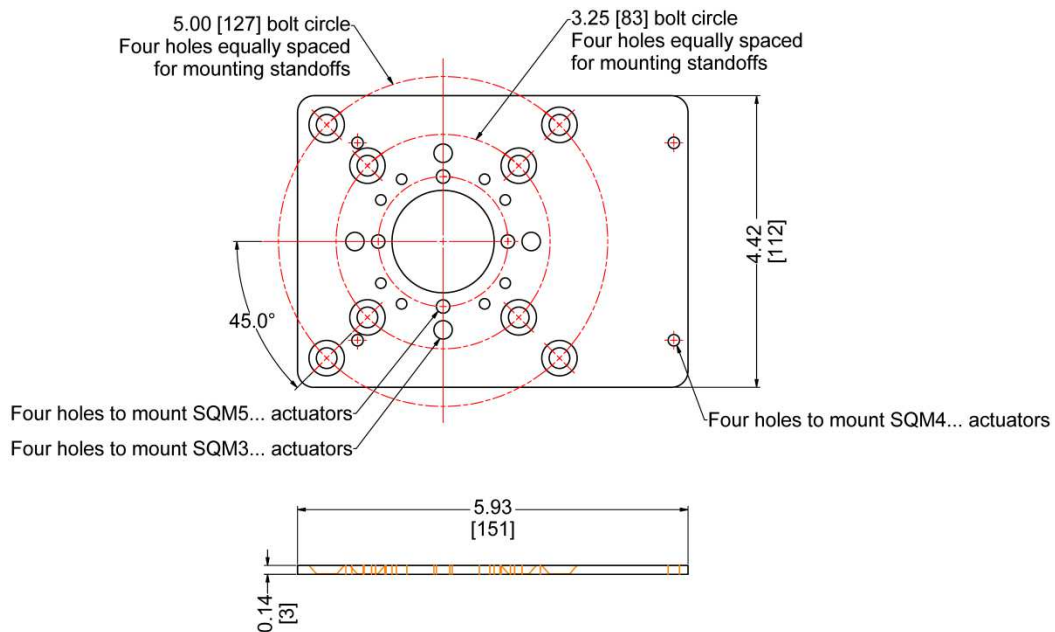

Dimensions (continued)

Dimensions in inches; millimeters in brackets

Actuator Bracket 3

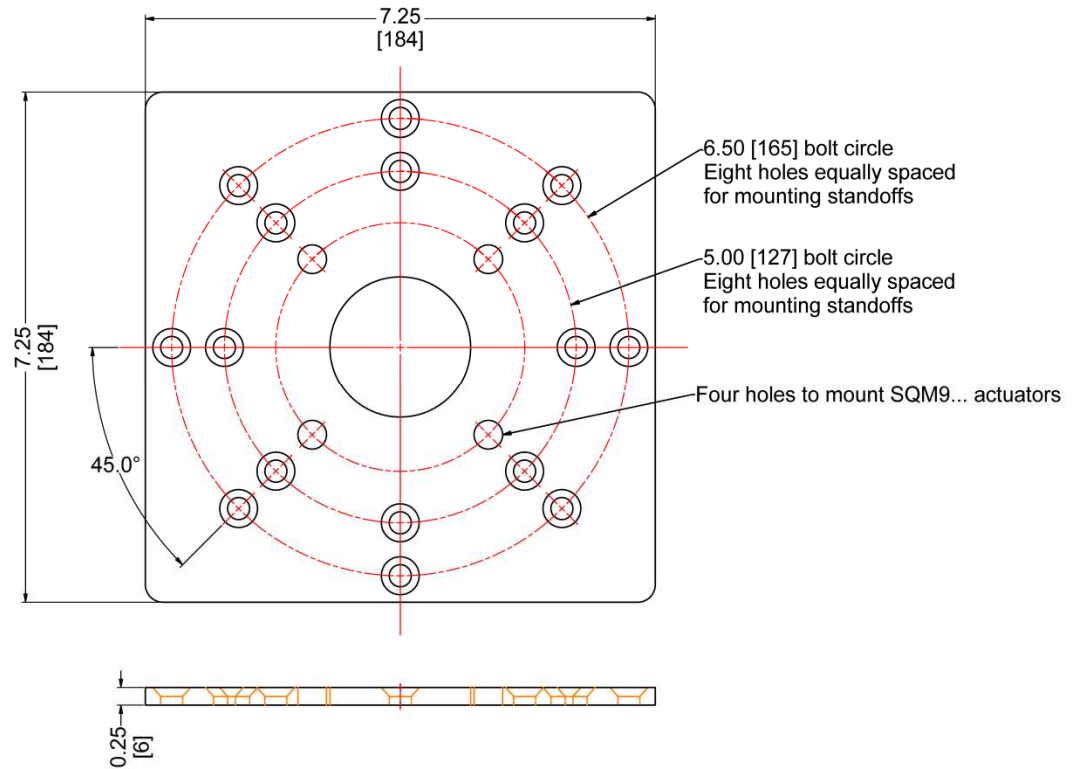

Dimensions (continued)

Dimensions in inches; millimeters in brackets

Mounting Option 1 - Pillow Block Bracket

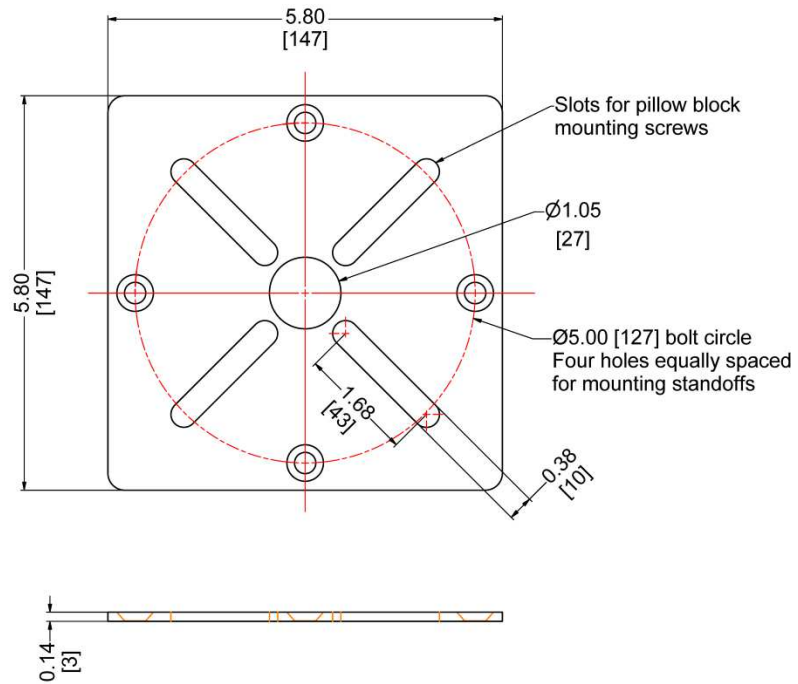

Mounting Option 2 - Weld Mounts

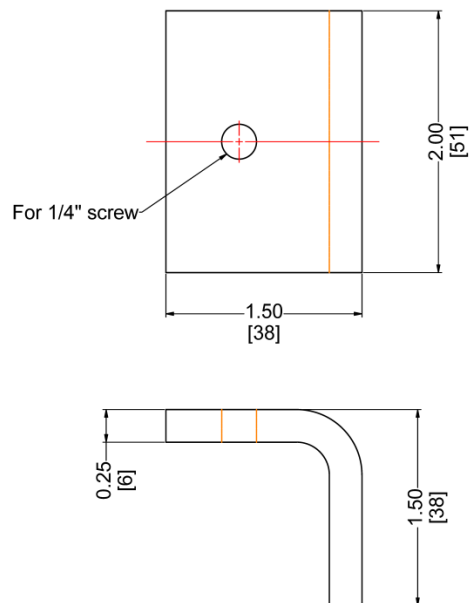

Dimensions (continued)

Dimensions in inches; millimeters in brackets

Mounting Option 3 - Blank Bracket

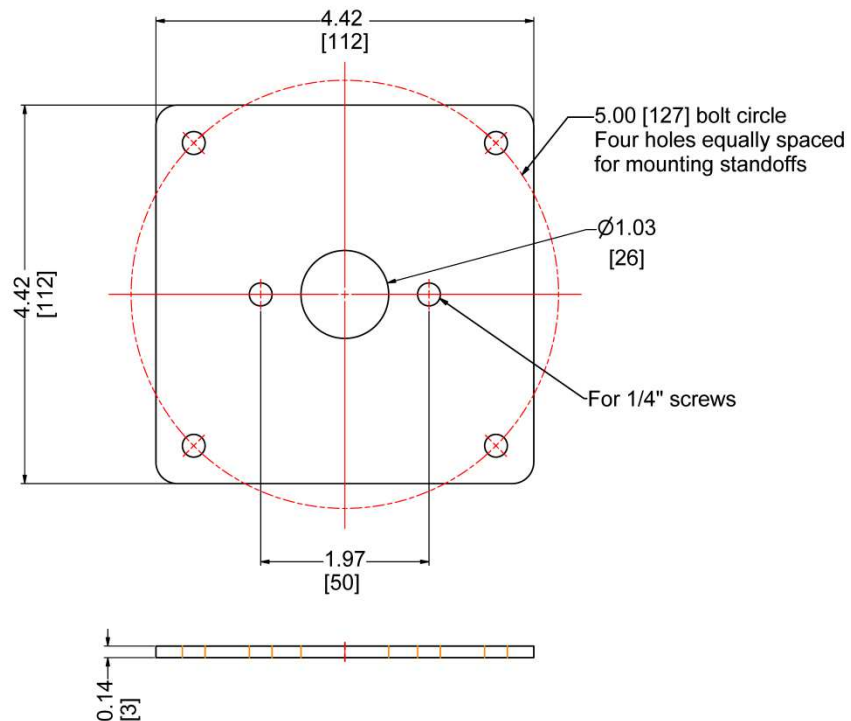

Standoffs

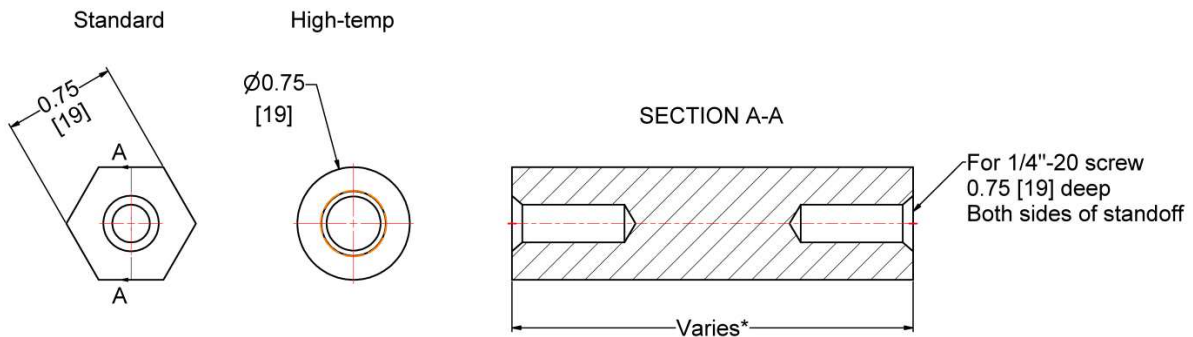

*Available standoff lengths are 2.80 [71], 2.90 [74], 3.00 [76], 3.80 [97], 3.90 [99], 4.15 [105], 4.50 [114], and 6.30 [160]

Dimensions (continued)

Dimensions in inches; millimeters in brackets

Bracket Assembly

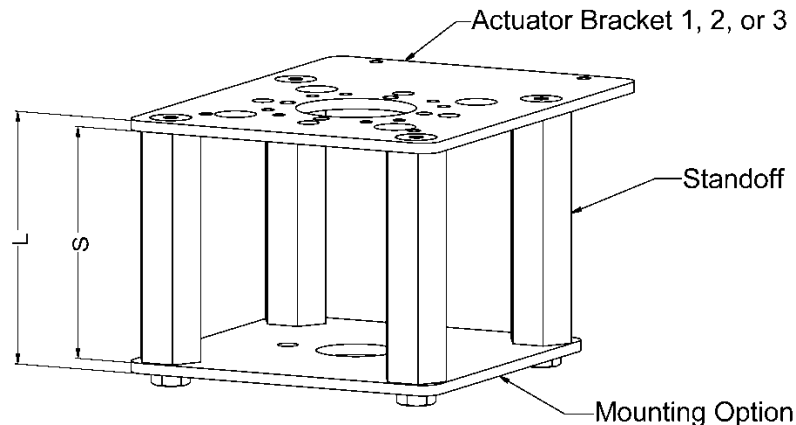

Table 5: Bracket Assembly Lengths

Actuator Bracket	Standoff Length (S)	Mounting Option			
		Pillow Block Bracket (L)	Weld Mounts (L)	Blank Bracket (L)	Threaded Studs (L)
1 or 2	2.80"	3.07 [78]	4.43 [113]	3.07 [78]	2.93 [74]
	2.90"	3.17 [81]	4.53 [115]	3.17 [81]	3.03 [77]
	3.00"	3.27 [83]	4.63 [118]	3.27 [83]	3.13 [80]
	3.80"	4.07 [103]	5.43 [138]	4.07 [103]	3.93 [100]
	3.90"	4.17 [106]	5.53 [140]	4.17 [106]	4.03 [102]
	4.15"	4.42 [112]	5.78 [147]	4.42 [112]	4.28 [109]
	4.50"	4.77 [121]	6.13 [156]	4.77 [121]	4.63 [118]
3	6.30"	6.57 [167]	7.93 [201]	6.57 [167]	6.43 [163]
	3.80"	4.18 [106]	5.54 [141]	4.18 [106]	4.04 [103]
	3.90"	4.28 [109]	5.64 [143]	4.28 [109]	4.14 [105]
	4.15"	4.53 [115]	5.89 [150]	4.53 [115]	4.39 [112]
	4.50"	4.88 [124]	6.24 [158]	4.88 [124]	4.74 [120]
	6.30"	6.68 [170]	8.04 [204]	6.68 [170]	6.54 [166]

Information in this publication is based on current specifications. The company reserves the right to make changes in specifications and models as design improvements are introduced. Product or company names mentioned herein may be the trademarks of their respective owners. © 2009 SCC Inc.