

Line Pressure Regulators Class I or Class II

FRS 7../6 Series

DUNGS®
Combustion Controls



CSA Certified

- ANSI Z21.80 / CSA 6.22 as a 5 PSI Class I or Class II Line Pressure Regulator
- File # 1205910

NPT Threaded Versions

- FRS 705/6 (1/2" NPT)
- FRS 707/6 (3/4" NPT)
- FRS 710/6 (1" NPT)
- FRS 712/6 (1 1/4" NPT)
- FRS 715/6 (1 1/2" NPT)
- FRS 720/6 (2" NPT)
- FRS 725/6 (2 1/2" NPT)
- FRS 730/6 (3" NPT)

Commonwealth of Massachusetts Approved Product

- Approval code G1-0911-83
- Gas pressure regulator

Codes and Standards

This product is intended for installations covered by but not limited to NFPA 54, CSA B149.1 and the International fuel gas code.

DUNGS is an ISO 9001 manufacturing facility.

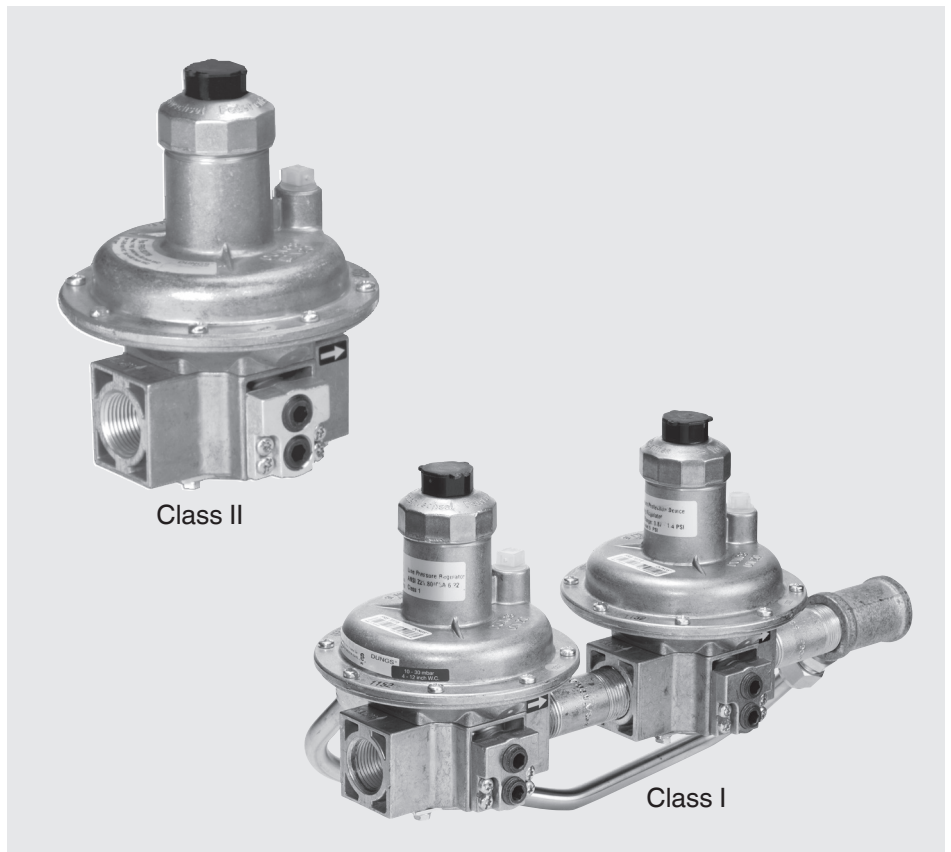

Description

The FRS 7../6 Line pressure regulators are a balancing type, spring-loaded regulator with an adjustable setpoint. They feature an internal sensor for regulating output pressure.

- Input pressures up to 7 PSI (See specifications for more details) and NPT 1/2" to NPT 3" thread connections (FRS 7../6)
- Heavy duty diaphragm construction for durability and strength.
- Steady, precise and instantaneous regulation of the outlet pressure.
- Lock-up type regulator (see page 2 and 3 for details).
- Factory installed vent limiter. Review applicable codes for vent line requirements.

Application

The FRS series line pressure regulators are recommended for applications when incoming gas pressure from the service regulator needs to be reduced to a suitable pressure for the gas appliance pressure regulator. These are designed for high efficiency appliances, high-turn down appliances, appliances using direct spark ignition or hot surface ignition, and other applications requiring a high performance regulator. The FRS is suitable for dry natural gas, propane, butane, air and inert gases.

The FRS does not contain any non-ferrous metals and is suitable for gases containing no more than 0.1% by volume, dry H₂S.

A "dry" gas has a dew point lower than +15 °F and its relative humidity is less than 60%.

FRS Spring-loaded pressure regulator with adjustable setpoint spring. Internal/External impulse for regulating output pressure.

Specifications

Body size pipe size (Type NPT)	705/6 1/2"	707/6 3/4"	710/6 1"	712/6 1 1/4"	715/6 1 1/2"	720/6 2"	725/6 2 1/2"	730/6 3"
Max. inlet operating pressure	7 PSI (500 mbar) at ambient +5 to +160 °F and outlet 4 - 80"WC. 5 PSI (350mbar) applies to CSA Certification.							
Input pressure range for optimal control	2 in. W.C. to 200 in. W.C. (5 mbar to 500 mbar)							
Max. body pressure	15 PSI (1000 mbar)							
Output pressure range	1 in. W.C. to 80 in. W.C. (2.5 mbar to 200 mbar). See spring selection below.							
Materials in contact with gas	Housing:				Aluminum, steel (free of non-ferrous metals)			
	Seals and diaphragms:				NBR-based rubber			
Ambient temperature	+5 °F to +160 °F for up to 10 PSI for regulating behavior (+/- 10% of setpoint). -40 °F to +160 °F for up to 5 PSI: Diaphragms are suitable for the low temperature, but there may be out of range regulating behavior. CSA Certified for -40 °F to +160 °F for up to 5 PSI.							
Installation position	Regulator dome from vertically upright to lying horizontally							
Vent line connection / vent limiter	Vent line connection is G 1/4" for FRS's up to 1" NPT, and it is G 1/2" for FRS's 1 1/4 to 3" NPT. The FRS also has a factory installed vent limiter, which limits the escape of gas to less than 0.5 CFH @ 5 PSI in case atmospheric diaphragm ruptures. Venting required unless otherwise accepted by the authority having jurisdiction.							
Turndown	Rated for 20:1							
Hysteresis and Droop	Hysteresis/repeatability is less than 10% for up to 7 PSI inlet. Average droop at 20:1 turndown is 10% for up to 7 PSI.							
Lock-up Rating	<ul style="list-style-type: none"> • The FRS meets the ANSI Z.21.80/CSA 6.22 as Class I, which allows lockup rating not more than 150% or 5 in. W.C, whichever is greater. • The FRS meets EN 88-1 as SG30, which allows lock-up as high as +30% of the outlet pressure. • See Lock-up pressure parameters on page 3 for more details 							

FRS 7../6 Class I	Order No.	Pressure max. [PSI]	Size	Dimensions [inch]						Weight [lbs] [kg]
				Dimensions [mm]						
				a	b	c	d	e	f	
FRS 705/6	267002	5	NPT 1/2	2.9 75	12.8 325	0.9 24	5.6 143	G 1/4	8.9 225	3.0 1,4
FRS 707/6	269320	5	NPT 3/4	3.9 100	14.7 373	1.1 28	6.5 165	G 1/4	9.6 245	5.0 2,3
FRS 710/6	269321	5	NPT 1	4.3 110	15.3 389	1.3 6	7.5 190	G 1/4	12.2 310	6.5 2,9
FRS 712/6	269322	5	NPT 1 1/4	5.9 150	19.1 485	1.6 40	9.8 250	G 1/2	14.2 365	13.0 5,9
FRS 715/6	267010	5	NPT 1 1/2	5.9 150	19.7 499	1.6 40	9.8 250	G 1/2	14.2 365	13.1 5,9
FRS 720/6	267012	5	NPT 2	6.7 170	21.8 553	1.9 47	12.2 310	G 1/2	17.7 450	17.0 7,7
FRS 725/6	269325	5	NPT 2 1/2	9.1 230	- -	3.7 95	15.9 405	G 1/2	23.2 590	- -
FRS 730/6	269328	5	NPT 3	10.4 265	- -	3.7 95	15.9 405	G 1/2	23.2 590	- -

FRS 7../6 Line Pressure Regulators Dimensions inch (mm)

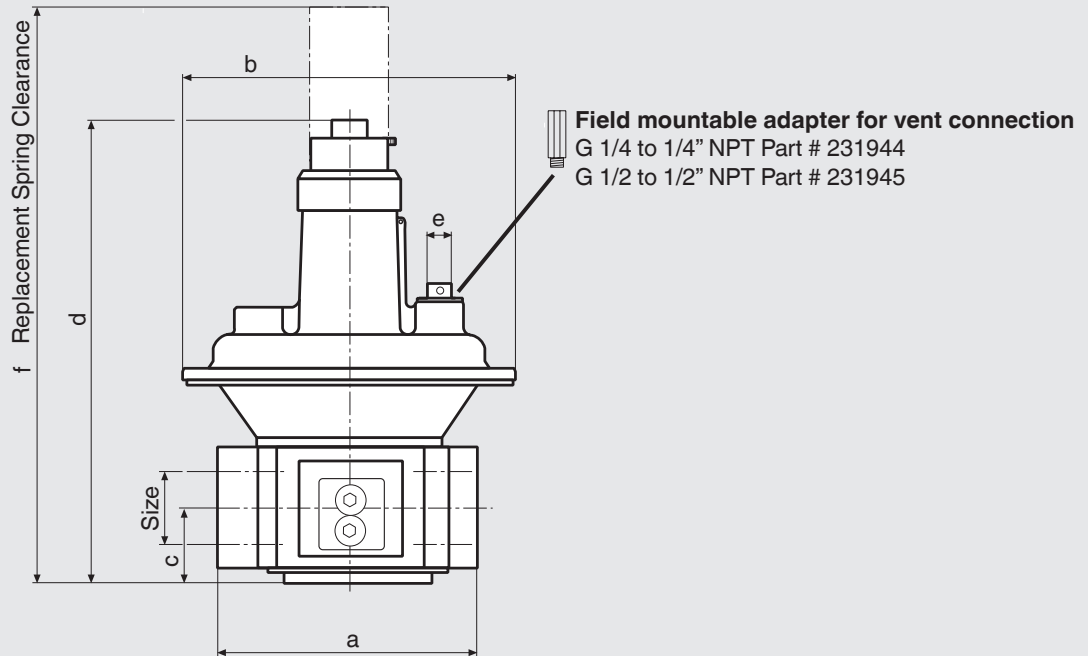

For Class I Regulators - „b“ is the total length of the regulator including OPD and fittings

FRS 7../6 Class II	Order No.	Pressure max. [PSI]	Size	Dimensions [inch] Dimensions [mm]						Weight [lbs] [kg]
				a	b	c	d	e	f	
FRS 705/6	269319	5	NPT 1/2	2.9 75	4.5 115	0.9 24	5.6 143	G 1/4	8.9 225	1.3 0,6
FRS 707/6	269320	5	NPT 3/4	3.9 100	5.1 130	1.1 28	6.5 165	G 1/4	9.6 245	2.2 1,0
FRS 710/6	267006	5	NPT 1	4.3 110	5.7 145	1.3 6	7.5 190	G 1/4	12.2 310	2.6 1,2
FRS 712/6	267008	5	NPT 1 1/4	5.9 150	7.7 195	1.6 40	9.8 250	G 1/2	14.2 365	5.9 2,7
FRS 715/6	269323	5	NPT 1 1/2	5.9 150	7.7 195	1.6 40	9.8 250	G 1/2	14.2 365	5.5 2,5
FRS 720/6	267013	5	NPT 2	6.7 170	9.8 250	1.9 47	12.2 310	G 1/2	17.7 450	7.7 3,5
FRS 725/6	269326	5	NPT 2 1/2	9.1 230	11.2 285	3.7 95	15.9 405	G 1/2	23.2 590	16.5 7,5
FRS 730/6	269329	5	NPT 3	10.4 265	11.2 285	3.7 95	15.9 405	G 1/2	23.2 590	22.0 10,0

Lock-up Rating Parameters

Per ANSI Z21.80, lock-up is defined as an outlet pressure not more than 150 % or 5 in. W.C., whichever is greater, above the setpoint after a downstream safety shutoff valve closes with 2 seconds, and the two following conditions exist:

- 1) outlet pressure is set to the highest set point of the spring, and
- 2) the regulator is set to maximum capacity or flow at which the regulator will control lockup pressure within the acceptable limits.

This means that in a given application, a lockup greater than 150 % or 5 in. W.C. could occur, depending on the

inlet pressure, the outlet pressure of the regulator, the flow rate of the regulator, and the pipe volume downstream the regulator and upstream the safety shutoff valve.

Per EN 88-1, lock-up is +30 % of the outlet pressure setting after downstream shutoff valve slowly closes within 30 seconds. Therefore, in a given application, a lockup greater than +30 % or 5 in. W.C. could occur, depending on the inlet pressure, the outlet pressure of the regulator, the flow rate of the regulator, and the pipe volume downstream the regulator and upstream the safety shutoff valve.

If in a given application the Lock-up pressure is too high, employing one or more of the following should reduce the lock-up pressure:

- 1) increase the size of the regulator.
- 2) increase the pipe volume downstream the regulator and upstream the safety shutoff valve.
- 3) decrease the inlet pressure.
- 4) decrease the outlet pressure.
- 5) reduce the flow rate.

Outlet Pressure Spring Selection (outlet pressure values are for horizontal pipe mounting)

The output pressure is controlled by the force of the adjustable spring. The pressure regulator is supplied with the blue spring No. 4. By exchanging springs, other output pressures can be attained. Subtract 1" W.C. when mounted vertically.

FRS 7../6 Type	Order No. as Class I	Regulator Outlet pressure range as Class I	Monitoring Regulator as Over-pressure Protection device. Outlet Pressure Protection Range
FRS 705/6	267002	4 - 12 in. W.C.	10 - 22 in. W.C.
FRS 707/6	269320	4 - 12 in. W.C.	10 - 22 in. W.C.
FRS 710/6	269321	4 - 12 in. W.C.	10 - 22 in. W.C.
FRS 712/6	269322	4 - 12 in. W.C.	10 - 22 in. W.C.
FRS 715/6	267010	4 - 12 in. W.C.	10 - 22 in. W.C.
FRS 720/6	267012	4 - 12 in. W.C.	10 - 22 in. W.C.
FRS 725/6	269325	4 - 12 in. W.C.	10 - 22 in. W.C.
FRS 730/6	269328	4 - 12 in. W.C.	10 - 22 in. W.C.

FRS 7../6 Type	Order No. as Class II	Regulator Outlet pressure range as Class II
FRS 705/6	269319	24 - 40 in. W.C.
FRS 707/6	267004	24 - 40 in. W.C.
FRS 710/6	267006	24 - 40 in. W.C.
FRS 712/6	267008	24 - 40 in. W.C.
FRS 715/6	269323	24 - 40 in. W.C.
FRS 720/6	267013	24 - 40 in. W.C.
FRS 725/6	269326	24 - 40 in. W.C.
FRS 730/6	269329	24 - 40 in. W.C.

Pressure Taps - FRS 7../6 Threaded Version

- 1 Vent/breather connection
FRS 705/6 - FRS 710/6, G 1/4 in.
FRS 712/6 - FRS 730/6, G 1/2 in.
- 2 External feedback pressure connection
FRS 705/6 - FRS 710/6, G 1/4 in. - one side.
FRS 712/6 - FRS 730/6, G 1/4 in. - both sides.
- 3 Upstream pressure connection
FRS 705/6 - FRS 710/6, 1/4 in. NPT - one side.
FRS 705/6 - FRS 710/6, G 1/4 in. - one side.
FRS 712/6 - FRS 730/6, 1/4 in. NPT - both sides.
- 4 Downstream pressure connection
FRS 705/6 - FRS 710/6, 1/4 in. NPT - one side.
FRS 712/6 - FRS 730/6 1/4 in. NPT - both sides.

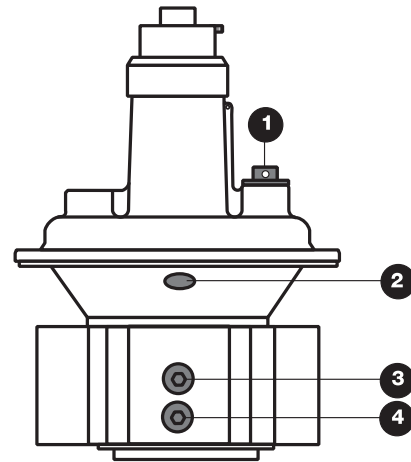

FRS 7../6 sectional drawing regulator in operating position

- 1 Housing
- 2 Regulating cup
- 3 Internal feedback tube
- 4 Balancing diaphragm
- 5 Diaphragm disk
- 6 Atmospheric diaphragm
- 7 Vent limiter
- 8 Vent line connection
- 9 Setpoint spring
- 10 Adjustment device

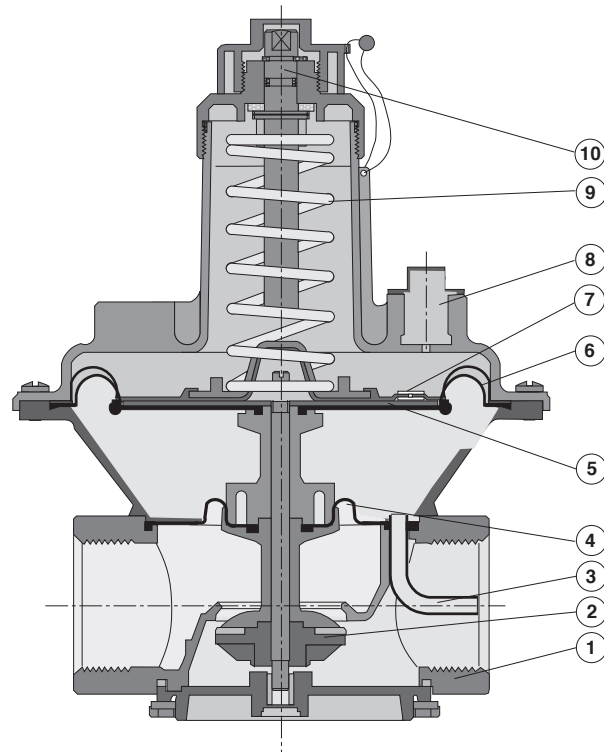

⚠ Protect the pressure regulator from debris by using a suitable filter.

Pressure drop for other gases

To determine the pressure drop when using a gas other than natural gas, use the flow formula below and f value located in the table below to determine

the “corrected” flow rate in CFH through the valve for the other gas used. For example, when using propane, divide the volume (CFH) of propane required for the application by the calculated value

f (f = 0.66 for propane). Use this “corrected” flow rate and the flow curve on the next page to determine pressure drop for propane.

Determining equivalent flow through valves using another gas

$$\dot{V}_{\text{gas used}} = \dot{V}_{\text{Natural gas}} \times f$$

$$f = \sqrt{\frac{\text{Density of Natural gas}}{\text{Density of gas used}}}$$

Type of gas	Density [kg/m ³]	s.g.	f
Natural gas	0.81	0.65	1.00
Butane	2.39	1.95	0.58
Propane	1.86	1.50	0.66
Air	1.24	1.00	0.80

Mechanically Opened Curve

Class II Regulator Pressure Drop Curve

Pressure drop for a Class I regulator is in worst case twice the value of the Class II regulator.

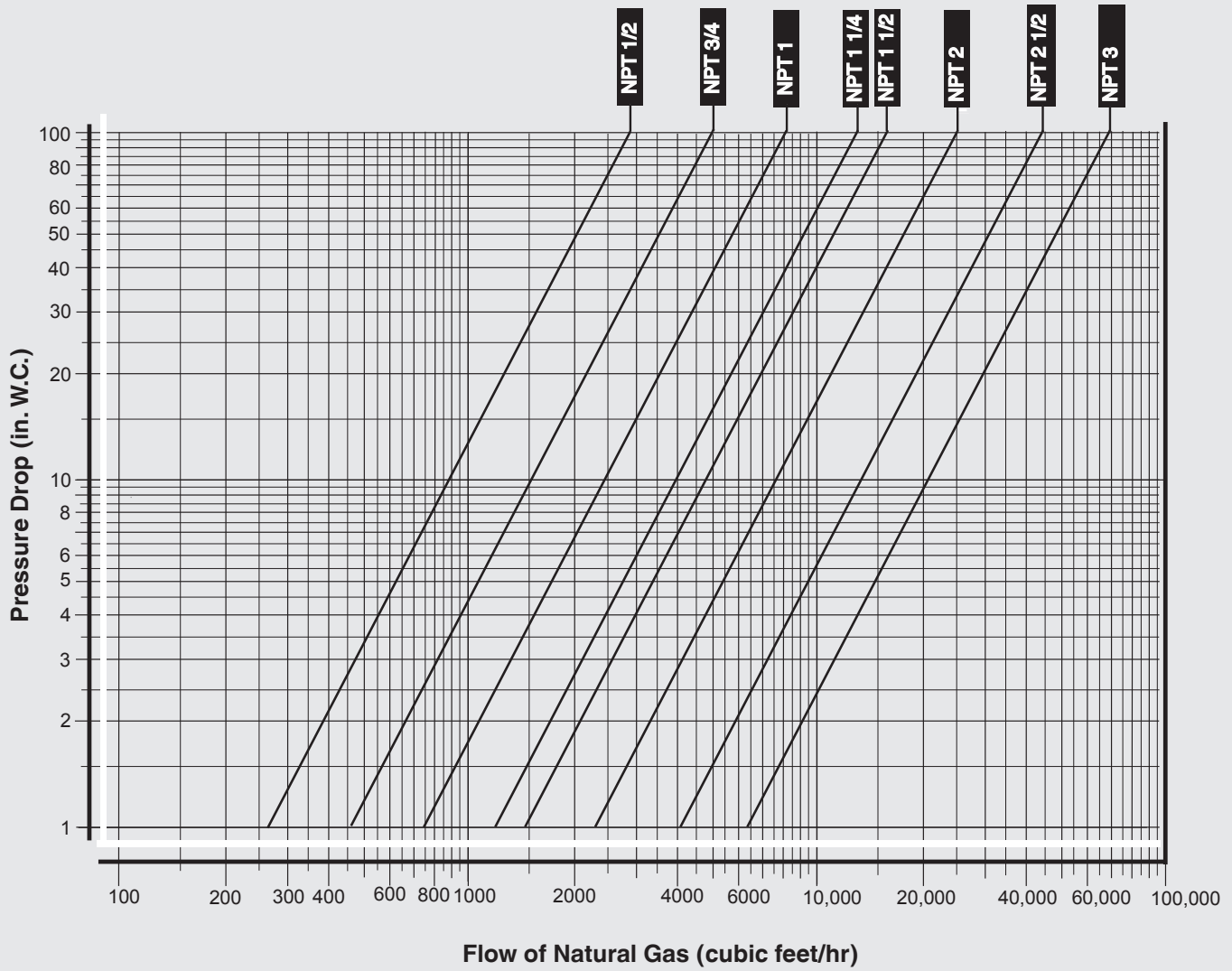

Flow Curve Using Natural Gas for class II regulator.
 Use as a quick reference for sizing a regulator in the regulated state at:
 Outlet pressure = 8 in. W.C.
 Inlet pressure = 20 in. W.C.
 $V_{min} = 0.05 \times V_{max}$
 Flow tables for other outlet pressures are available
 Pressure drop for a Class I regulator is in worst case twice the value of the Class II regulator.

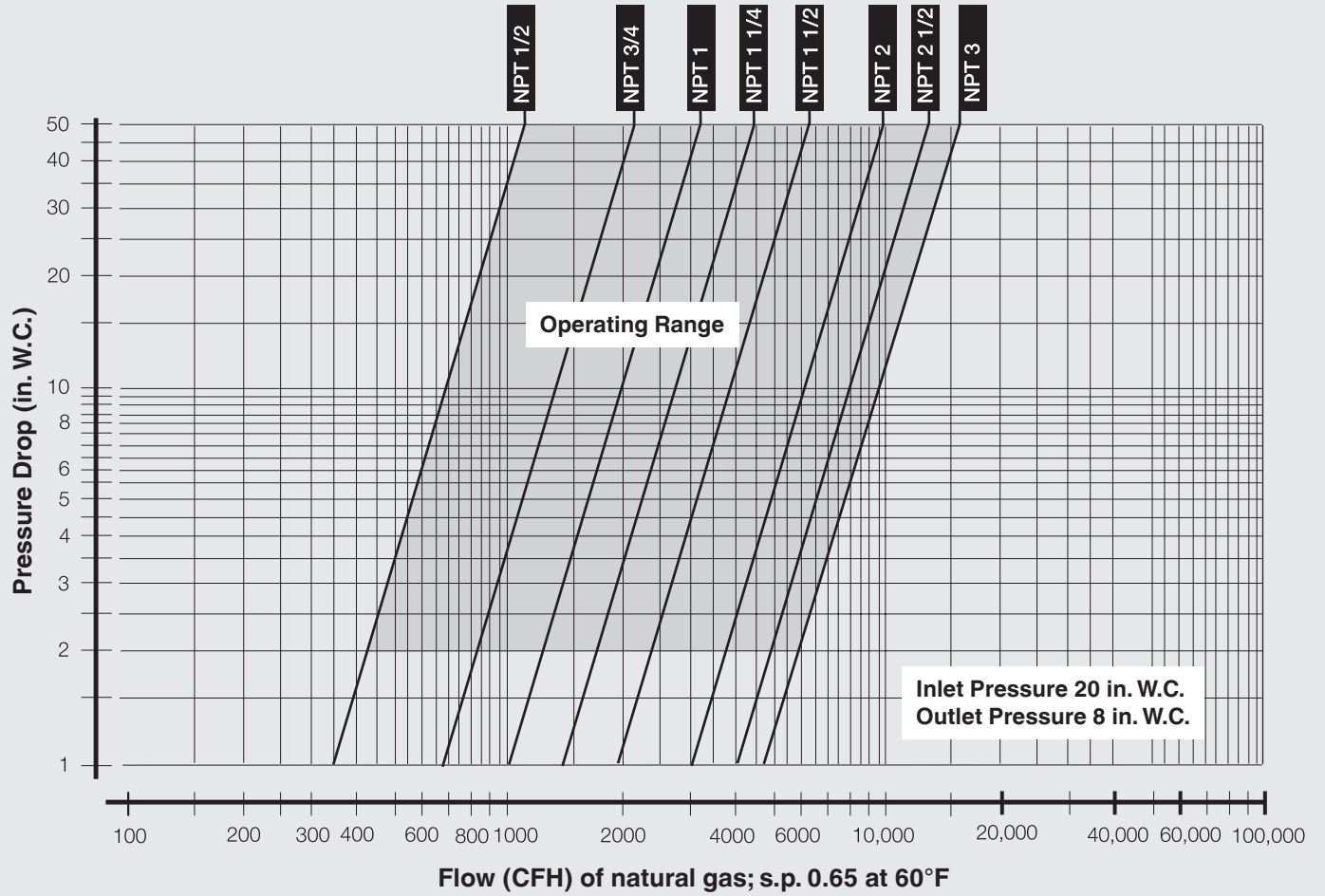

**Line Pressure Regulators
Class I or Class II**

FRS 7../6 Series



We reserve the right to make any changes in the interest of technical progress.

Karl Dungs, Inc.
3890 Pheasant Ridge Drive NE
Suite 150
Blaine, MN 55449, U.S.A.
Phone 763 582-1700
Fax 763 582-1799
e-mail info@karldungsusa.com
Internet <http://www.dungs.com/usa/>

Karl Dungs GmbH & Co. KG
P.O. Box 12 29
D-73602 Schorndorf, Germany
Phone +49 (0)7181-804-0
Fax +49 (0)7181-804-166
e-mail info@dungs.com
Internet <http://www.dungs.com>