

Operating instructions

Burners for gas ZIC

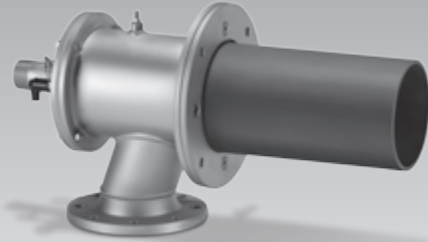

Contents

Burners for gas ZIC	1
Contents	1
Safety	1
Checking the usage	2
Installation	3
Installing the ceramic tube	3
Installation on the furnace	4
Air connection, gas connection	4
Installing the burner insert	5
Wiring	5
Preparing commissioning	6
Determining the flow rates	6
Notes on the flow rate curve	7
Restrictors	7
Hot-air compensation	7
Commissioning	8
Igniting and adjusting the burner	8
Tightness test	9
Cooling air	9
Blocking and recording the settings	10
Maintenance	10
Assistance in the event of malfunction	12
Accessories	12
Technical data	13
Logistics	13
Declaration of Incorporation	14
Certification	14
Contact	14

Safety

Please read and keep in a safe place



Please read through these instructions carefully before installing or operating. Following the installation, pass the instructions on to the operator. This unit must be installed and commissioned in accordance with the regulations and standards in force. These instructions can also be found at www.docuthek.com.

Explanation of symbols

■, **1**, **2**, **3**... = Action

> = Instruction

Liability

We will not be held liable for damage resulting from non-observance of the instructions and non-compliant use.

Safety instructions

Information that is relevant for safety is indicated in the instructions as follows:

⚠ DANGER

Indicates potentially fatal situations.

⚠ WARNING

Indicates possible danger to life and limb.

! CAUTION

Indicates possible material damage.

All interventions may only be carried out by qualified gas technicians. Electrical interventions may only be carried out by qualified electricians.

Conversion, spare parts

All technical changes are prohibited. Only use OEM spare parts.

Changes to edition 11.11

The following chapters have been changed:

- Checking the usage
- Installation
- Preparing commissioning
- Commissioning
- Technical data
- Logistics
- Declaration of Incorporation

Checking the usage

Burner for heating industrial thermoprocessing equipment. The burner ZIC can be used in conjunction with the ceramic tube set TSC in industrial furnaces or firing systems with brick lining or ceramic fibre lining. No burner quartz is necessary. For natural gas, town gas and LPG. Other types of gas on request. This function is only guaranteed when used within the specified limits – see also page 13 (Technical data). Any other use is considered as non-compliant.

Burner

Construction stage, rated capacity Q_{max} , gas type – see type label.

D-49018 Osnabrück, Germany		kromschroder	
ZIC 165HB-0/35-(18)D			D
BR 84246518	BE 74970471	BK 18	
Q_{max} 630 kW	Gas N	SN	17.11.

Type code

Code	Description
ZIC	Burner for gas with cast steel housing
ZICW	Burner for gas with cast steel housing and internal insulation
165-200	Burner size
R	Normal flame
H	Long, soft flame
B	Natural gas
G	Butane, propane, propane/butane
M	Butane, propane, propane/butane
L	Low calorific value gas
D	Coke oven gas, town gas
L	Ignition lance
R	Reduced max. connection rating
	Length of burner extension [mm]:
-0	none
-100	100
-200...	200
/35-	
/135-	Position of burner head [mm]
/235-...	
-(1) to	Burner head identifier
-(199)	
-(1E) to	High temperature version
-(199E)	
A-F	Construction stage

Part designations

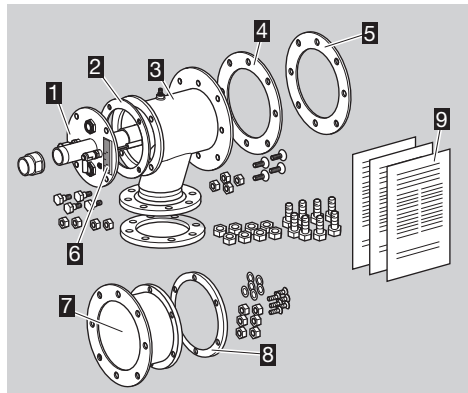

- 1** Burner insert
 - 2** Gas housing gasket
 - 3** Air housing
 - 4** Mounting flange
 - 5** Mounting gasket
 - 6** Type label
 - 7** Burner extension (for ZIC..-100, ZIC..-200)
 - 8** Clamping ring
 - 9** Enclosed documentation (flow rate curves, operating characteristic diagrams, dimension sheet, spare parts list, spare parts drawing and Declaration of Incorporation)
- Check letter marking and identification marks on the burner head using the information provided on the type label.

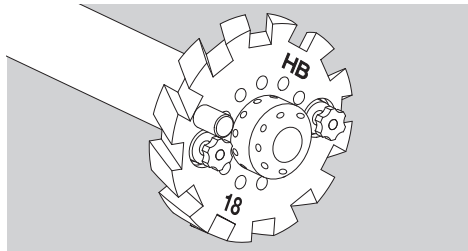

Ceramic tube

Length and diameter – see type label.

D-49018 Osnabrück, Germany		kromschroder	
TSC 165A154-300/35-Si-1500			
RS	MA	Si-1500	SN

Type code

Code	Description
TSC	Ceramic tube set
165 - 200	Burner size
A	Cylindrical
154, 180	Outlet dia. D4 [mm]
-300	Tube length L8 [mm]
/35-	Position of burner head L9 [mm]
Si-1500	Ceramic tube material

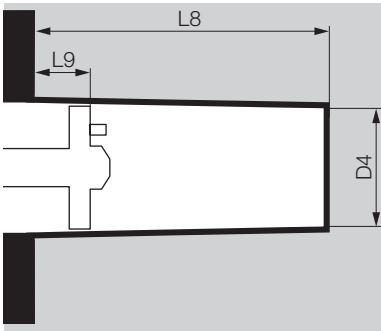

Part designations

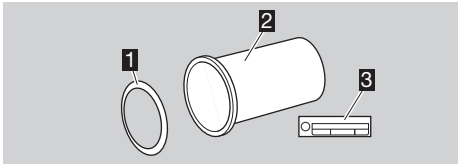

- 1 Burner tube gasket
- 2 Ceramic tube
- 3 Type label

Installation

Installing the ceramic tube

! CAUTION

Install the ceramic tube centrally and free of mechanical stress to avoid damage. Remove and dispose of the transport safety device; to do this, remove the mounting flange or clamping ring.

- ▷ Remove the burner insert in order to install the ceramic tube. For this purpose, the air housing can be placed in a vertical position on a smooth working surface.
- ▷ On ZICW, avoid the formation of dust when dismantling the burner insert and do not damage the surface of the internal insulation.

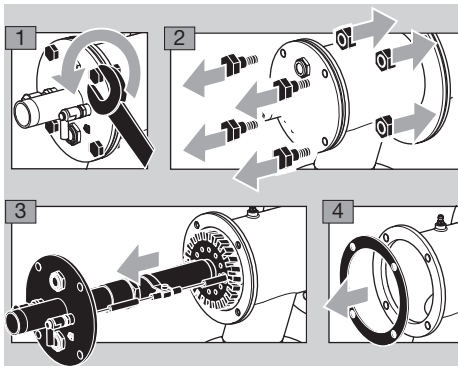

- 5 Place the burner insert in such a way that the insulators are protected against damage.

No burner extension

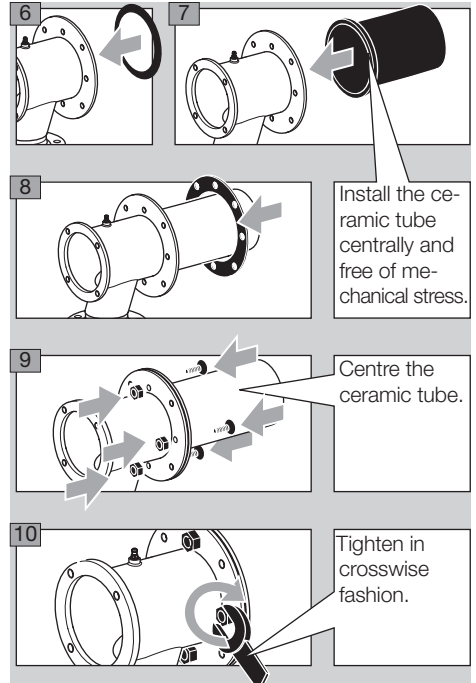

Install the ceramic tube centrally and free of mechanical stress.

Centre the ceramic tube.

Tighten in crosswise fashion.

With burner extension

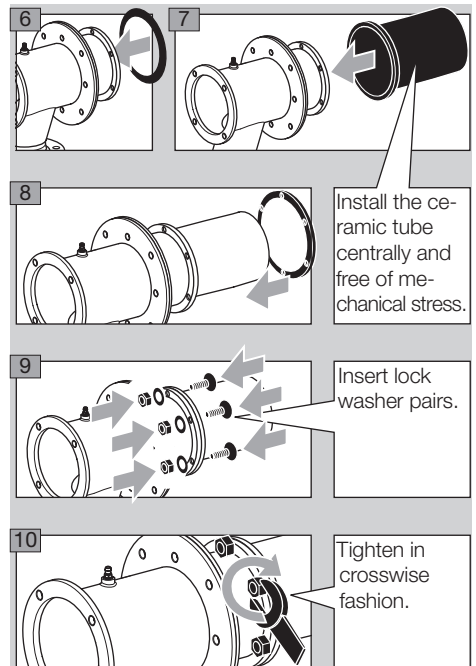

Install the ceramic tube centrally and free of mechanical stress.

Insert lock washer pairs.

Tighten in crosswise fashion.

Insulating the ceramic tube

- ▷ Protect the burner extension from thermal stress.
- ▷ We recommend solid shaped parts **A** or high temperature resistant ceramic fibrous material **B** for insulation.
- ▷ Observe an annular gap of at least 10 mm (0.4").
- 11** Insulate the ceramic tube at least as far as the burner head, to a maximum of 20 mm (0.8") behind the burner head.
- ▷ Burner without extension:

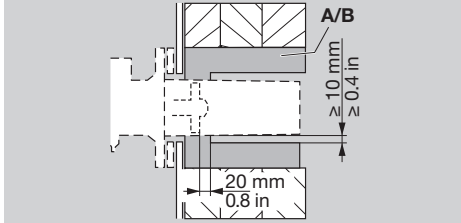

- ▷ Burner with extension:

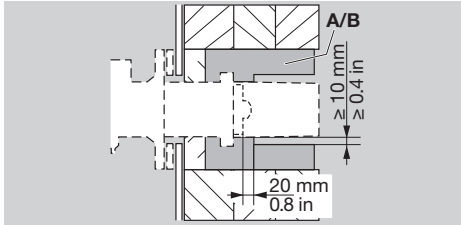

Installation on the furnace

- ▷ When installing, always ensure that when the burner is mounted, it is sealed tightly on the furnace wall.

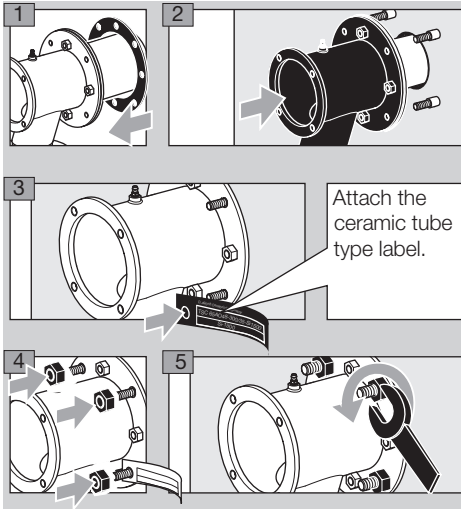

Air connection, gas connection

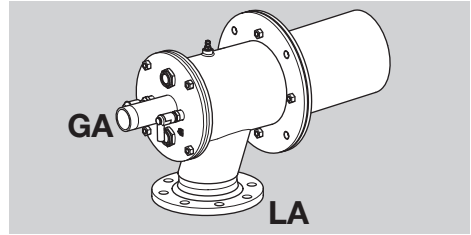

Type	Gas connection GA	Air connection LA
ZIC 165	Rp 1½	DN 100
ZIC 200	Rp 2	DN 150

- ▷ Threaded connection to DIN 2999, flange dimensions to DIN 2633, PN 16.
- ▷ Install flexible tubes or bellows units to prevent mechanical stress or transmission of vibration.
- ▷ Ensure that the seals are undamaged.

⚠ DANGER

Risk of explosion! Ensure the connection is gas-tight.

Connection to ANSI/NPT

- ▷ An adapter set is required for connection to ANSI/NPT, see page 12 (Adapter set).

Type	Gas connection GA	Air connection LA*
ZIC 165	1½ – 11.5 NPT	4.57"
ZIC 200	1½ – 11.5 NPT	6.72"

* Flange hole diameter.

- ▷ Weld flange **J** to air pipe **P** for air connection **LA** and use NPT thread adapter **H** for gas connection **GA**.

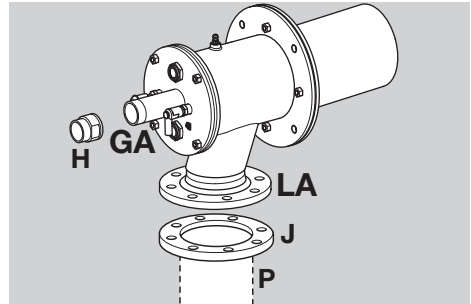

- ▷ The nozzle set with NPT coupling is required for integrated ignition lances, see page 12 (Nozzle set).

Ignition lance connections on the ZIO..L:

- ▷ Air connection **la**.
- ▷ Gas connection **ga**.
- ▷ Ignition lance capacity: 1.5 kW.

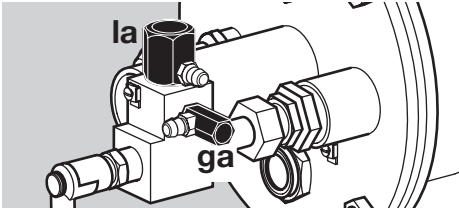

Type	Ignition lance gas connection	Ignition lance air connection
ZIC..L	Rp ¼	Rp ½
ZIC..L with adapter set	¼" NPT	½" NPT

Installing the burner insert

- ▷ The burner insert can be rotated to the required position in increments of 90°.
- ▷ Insert the gas housing gasket between the burner insert and the air housing.
- ▷ On ZICW, avoid the formation of dust and do not damage the surface of the internal insulation.

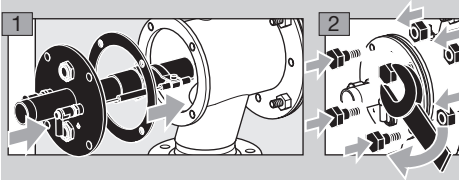

- ▷ Tighten the burner insert in a crosswise fashion with max. 37 Nm (27.3 lbf ft).

Wiring

⚠ DANGER

Electric shocks can be fatal! Before working on possible live components, ensure the unit is disconnected from the power supply.

- ▷ For the ignition and ionization cables, use (un-screened) high-voltage cable:
 - FZLSi 1/6 up to 180°C (356°F), Order No. 04250410, or
 - FZLK 1/7 up to 80°C (176°F), Order No. 04250409.

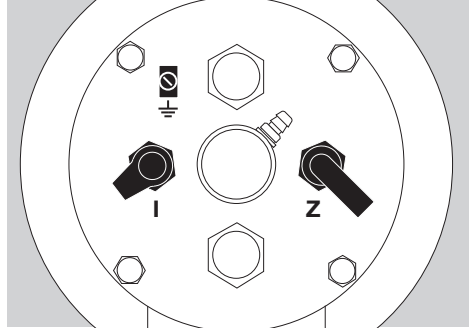

Ionization electrode I

- ▷ Install the ionization cable well away from mains cables and interference from electro-magnetic sources and avoid external electrical interference. Max. length of ionization cable – see automatic burner control unit operating instructions.
- ▷ Connect the ionization electrode to the automatic burner control unit via the ionization cable.

Ignition electrode Z

- ▷ Length of ignition cable: max. 5 m (15 ft), recommended < 1 m (40").
- ▷ For permanent ignition, max. ignition cable length 1 m (40").
- ▷ Lay the ignition cable individually and not in a metal conduit.
- ▷ Install the ignition cable separately from ionization and UV cables.
- ▷ A ≥ 7.5 kV, ≥ 12 mA ignition transformer is recommended; 5 kV for ignition lance.

Ionization and ignition electrodes

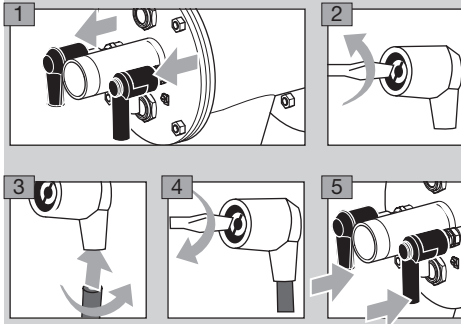

- 6 Connect the PE wire for burner ground to the burner insert. In the case of single-electrode operation, route the PE wire from the burner insert directly to the terminal on the automatic burner control unit.

⚠ WARNING

High-voltage risk! It is essential that a high-voltage warning label is attached to the ignition cable.

- 7 For more detailed information on how to wire the ionization and ignition cables, refer to the operating instructions and connection diagrams of the automatic burner control unit and ignition transformer.

Preparing commissioning

Safety instructions

- ▷ Arrange the adjustment and commissioning of the burner with the system operator or manufacturer.
- ▷ Check the entire system, upstream devices and electrical connections.
- ▷ Note the operating instructions for individual controls.

⚠ DANGER

The burner must only be commissioned by authorized trained personnel.

Risk of explosion! Please observe the appropriate precautions when igniting the burner.

Risk of poisoning! Open the gas and air supply so that the burner is always operated with excess air – otherwise CO will form in the furnace chamber. CO is odourless and poisonous! Conduct a flue gas analysis.

- ▷ Pre-purge the furnace chamber with air (5 x furnace chamber volume) before every ignition attempt.
- ▷ If the burner does not ignite although the automatic burner control unit has been switched on and off several times: check the entire system.

- ▷ After ignition, monitor the flame and the gas and air pressure measured on the burner. Measure the ionization current. Switch-off threshold – see automatic burner control unit operating instructions.

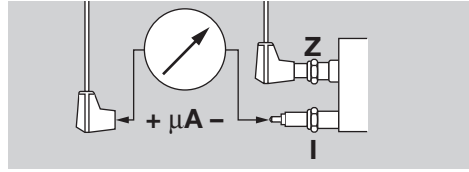

- ▷ The burner must only be ignited at low fire (between 10 and 30% of the rated capacity Q_{max}) – see type label).

⚠ DANGER

Risk of explosion! Fill the gas line to the burner carefully and correctly with gas and vent it safely into the open air – do not discharge the test volume into the furnace chamber.

Determining the flow rates

$$Q_{Gas} = P_B / H_U$$

$$Q_{Luft} = Q_{Gas} \cdot \lambda \cdot L_{min}$$

- ▷ Q_{Gas} : Gas flow rate in m³/h (ft³/h)
- ▷ P_B : Burner capacity in kW (BTU/h)
- ▷ H_U : Gas calorific value in kWh/m³ (BTU/ft³)
- ▷ Q_{Luft} : Air flow rate in m³_(n)/h (SCFH)
- ▷ λ : Lambda, air index
- ▷ L_{min} : Minimum air requirement in m³_(n)/m³_(n) (SCF/SCF)
- Use the lower calorific value H_U .
- ▷ Information on the gas quality supplied can be obtained from the competent gas supply company.

Common gas qualities

Gas type	H_U kWh/m ³ _(n) (BTU/SCF)	L_{min} m ³ _(n) /m ³ _(n) (SCF/SCF)
Natural gas H	11 (1114)	10.6
Natural gas L	8.9 (901)	8.6
Propane	25.9 (2568)	24.4
Town gas	4.09 (425)	3.67
Butane	34.4 (3406)	32.3

* Data in kWh/m³_(n) refer to the lower calorific value H_U and data in BTU/SCF refer to the upper calorific value H_o .

- ▷ For safety reasons, a minimum air excess of 5% (lambda = 1.05) should be ensured.

Notes on the flow rate curve

- ▷ If the gas density in the operating state differs from that reflected in the flow rate curve, convert the pressures according to the local operating state.

$$P_B = P_M \cdot \frac{\delta_B}{\delta_M}$$

- ▷ δ_M : Gas density reflected in the flow rate curve [kg/m³ (lb/ft³)]
- ▷ δ_B : Gas density in operating state [kg/m³ (lb/ft³)]
- ▷ P_M : Gas pressure reflected in the flow rate curve
- ▷ P_B : Gas pressure in operating state
- Read off the gas pressure p_{gas} and air pressure p_{air} from the enclosed flow rate curve for cold air on the basis of the calculated flow rates.

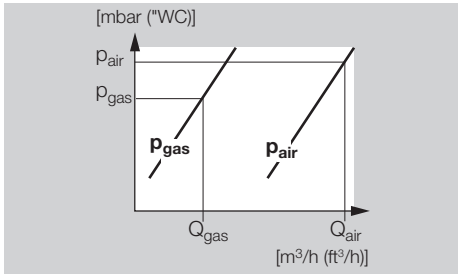

- ▷ Note possible capacity changes due to positive or negative pressures in the furnace/combustion chamber. Add positive pressures or subtract negative pressures.
- ▷ As not all the effects caused by the equipment are known, setting the burner using the pressure values is only approximate. It is possible to set the burner precisely by measuring the flow rates or flue gas.

Restrictors

- ▷ The air volume required for the low-fire rate at a given air pressure is determined by the ignition position of a butterfly valve, a bypass hole in the air valve or an external bypass with restrictor.

Hot-air compensation

- ▷ The combustion air pressure P_{Air} must be increased in hot-air operating mode (lambda = constant).

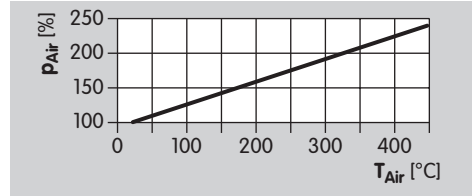

- ▷ The gas pressure is increased by 5 – 10 mbar.
- ▷ The total burner capacity P_B rises as the air temperature T_{Air} increases.

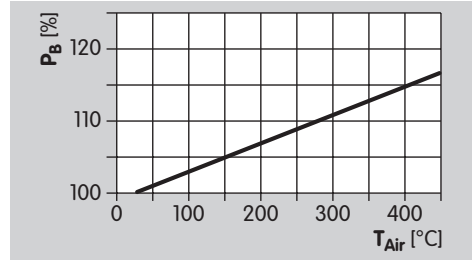

Setting the air pressure for low fire and high fire

- 1 Shut off the gas and air supply.
- ▷ Air measuring nipple **L**, external dia. = 9 mm (0.35").

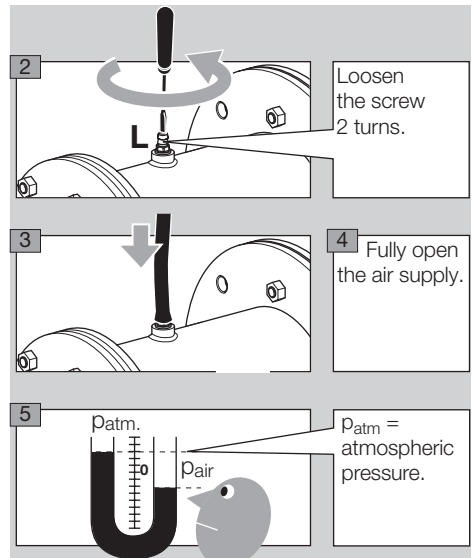

Low fire:

- ▷ The burner must only be ignited at low fire (between 10 and 30% of the rated capacity Q_{\max} – see type label).
- Reduce the air supply on the air control valve and set the desired low-fire rate, e.g. using a limit switch or mechanical stop.
- ▷ On air control valves with bypass, the bypass orifice should be determined on the basis of the required flow rate and the existing supply pressure if required.

High fire:

- Set the required air pressure p_{air} on the air restrictor upstream of the burner.
- When using air restricting orifices: check the air pressure p_{air} .

Preparing the gas pressure measurement for low fire and high fire

- Connect all measuring devices for subsequent fine adjustment of the burner.
- ▷ Leave the gas supply closed.
- ▷ Gas measuring nipple **G**, external dia. = 9 mm (0.35").
- Read off the gas pressure p_{gas} for the required flow rate from the enclosed flow rate curve for cold air.

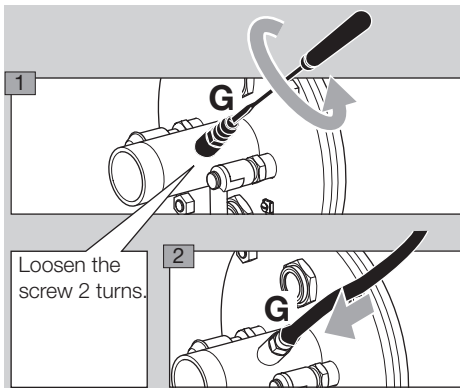
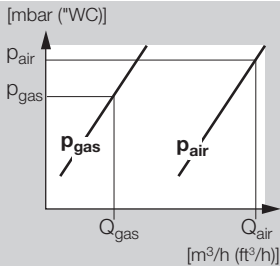

Integrated ignition lance on the ZIC..L:

- ▷ Air pressure test nipple **I**, external dia. = 9 mm (0.35").
- ▷ Gas pressure test nipple **g**, external dia. = 9 mm (0.35").

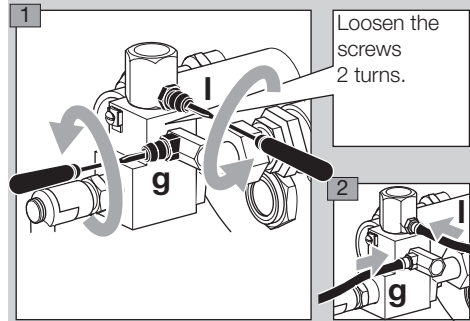

- ▷ Ignition lance:
 $p_{\text{gas}} = 30 - 50 \text{ mbar}$,
 $p_{\text{air}} = 30 - 50 \text{ mbar}$.
- ▷ Check flame stability and ionization current.
- ▷ The gas and air pressure of the ignition lance must be higher than the gas and air pressure of the main burner.

Commissioning

Igniting and adjusting the burner

⚠ WARNING

Ensure adequate ventilation of the furnace chamber before each burner start!

- ▷ The burner housing will become hot during operation with preheated combustion air. Provide protection against accidental contact as required.
- All valves of the installation must be checked for tightness before ignition.

Setting the low-fire rate:

- Set the valves to ignition position.
- Limit the maximum gas volume.
- ▷ Should an adjustable gas restrictor be installed upstream of the burner, open the restrictor by approx. a quarter.
- Open the gas supply.
- Ignite the burner.
- ▷ The safety time of the automatic burner control unit starts to elapse.
- If no flame forms, check and adjust the gas and air pressures of the start gas adjustment.
- In the case of operation with bypass (e.g. when using an air/gas ratio control): check the bypass nozzle and adjust if required.
- In the case of operation without bypass (e.g. when using an air/gas ratio control without bypass): increase the low-fire rate setting.
- Check the basic setting or bypass of the air control valve.

- Check the position of the restrictor in the air line.
 - Check the fan.
 - Reset the automatic burner control unit and re-ignite the burner.
- ▷ The burner ignites and proceeds to normal operation.
- Check flame stability and ionization current at low fire. Switch-off threshold – see automatic burner control unit operating instructions.

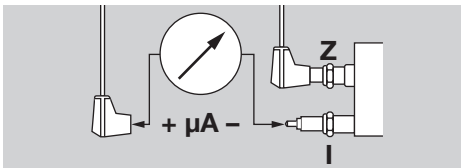

- Monitor flame formation.
- Adjust the low-fire rate settings if required.
- If no flame forms – see page 12 (Assistance in the event of malfunction).

Setting the high-fire rate:

- Set the air and gas circuit of the burner to high fire while continuously monitoring the flame.
- ▷ Avoid CO formation – always operate the burner with excess air when starting up!
- ▷ When the desired maximum valve positions are reached, set the gas pressure p_{gas} using the restrictor upstream of the burner.

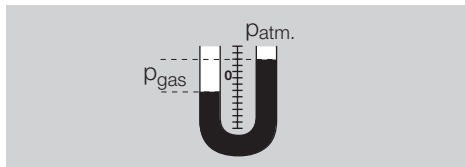

Re-adjusting the air flow rate:

- Check the air pressure p_{air} on the burner and adjust using the air restrictor if required.
- When using air restricting orifices: check the air pressure p_{air} and rework the orifice if required.

⚠ DANGER

Risk of explosion and poisoning during burner adjustment with an air deficiency!

Adjust the gas and air supply so that the burner is always operated with excess air – otherwise CO will form in the furnace chamber. CO is odourless and poisonous! Conduct a flue gas analysis.

- Measure the gas and air flow rates if possible. Determine the lambda value and re-adjust the settings if required.

Tightness test

⚠ DANGER

To ensure that there is no danger resulting from a leak, check the gas connections on the burner for leaks immediately after the burner has been put into operation.

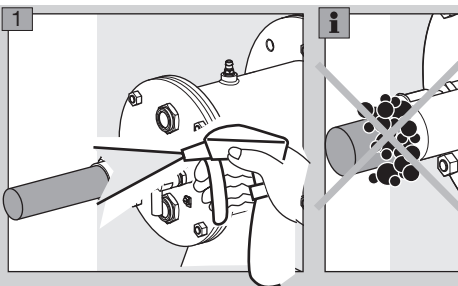

- ▷ Avoid condensation due to the furnace atmosphere entering the burner housing. While the burner is switched off, at furnace temperatures above 500°C (932°F), it must be cooled with a low air volume – see page 9 (Cooling air).

Cooling air

- ▷ While the burner is switched off and depending on the furnace temperature, there must be a certain air flow for cooling the burner components

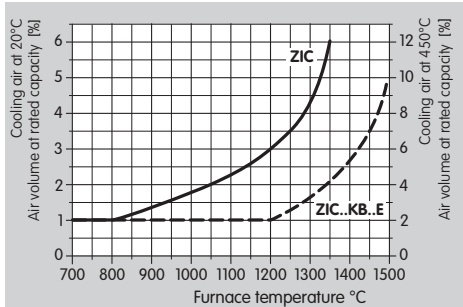

- ▷ Diagram: the relative air volume in percentage values, based on the air volume for the rated capacity of the relevant size, is given in the diagram. For hot air (450°C), the values on the right-hand axis are based on the standard air volume for the relevant rated capacity.
- ▷ Leave the air fan switched on until the furnace has cooled down completely.

Blocking and recording the settings

- 1 Produce a measurement report.
- 2 Set the burner to low fire and check the settings.
- 3 Set the burner to low and high fire several times while monitoring the pressure settings, flue gas values and flame patterns.
- 4 Remove the measuring devices and close off the test nipples – tighten the grub screws.
- 5 Block and seal the adjusting elements.
- 6 Induce a flame failure, e.g. by pulling the plug off the ionization electrode. The flame detector must close the gas safety valve and signal a fault.
- 7 Switch the system on and off several times while monitoring the automatic burner control unit.
- 8 Produce an acceptance report.

⚠ DANGER

An incorrect change of the burner settings may change the gas/air ratio and lead to unsafe operating conditions. Risk of explosion in case of CO being formed in the furnace chamber! CO is odourless and poisonous!

Maintenance

We recommend that a function check is carried out every six months.

⚠ WARNING

Risk of burning! Outflowing flue gases and burner components are hot.

- 1 Check the ionization and ignition cables.
 - 2 Measure the ionization current.
- ▷ The ionization current must be at least 5 μA and must not vary.

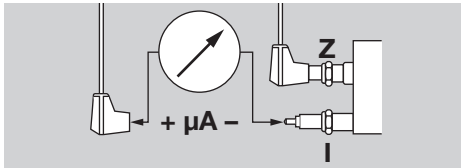

- 3 Disconnect the system from the electrical power supply.
- 4 Shut off the gas and air supply – do not change the restrictor settings.

Checking the ignition and ionization electrodes

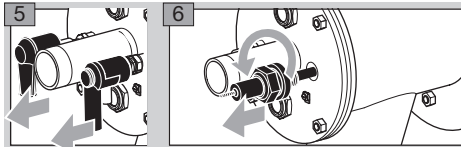

- ▷ Ensure that the electrode length does not change.
- 7 Remove dirt from electrodes or insulators.

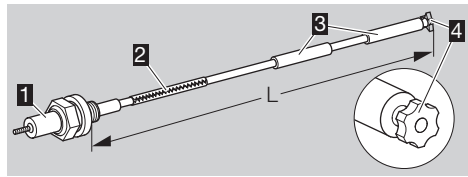

- 8 If the star 4 or insulator 3 is damaged, replace the electrode.
- ▷ Before changing the electrode, measure the total length L.
- 9 Connect the new electrode with the spark plug 1 using the dowel pin 2.
 - 10 Adjust spark plug and electrode to the measured total length L.

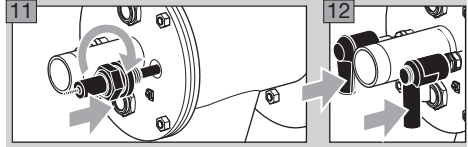

- ▷ Turning the spark plug makes it easier to feed the electrode into the burner insert.

Checking the burner

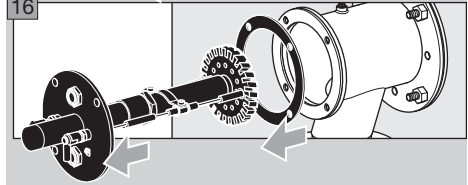
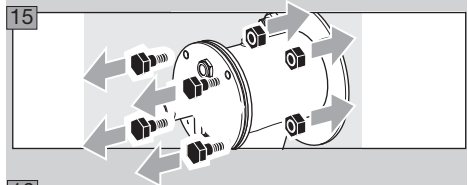
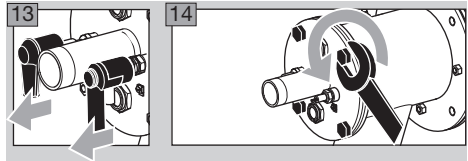

- ▷ If the burner insert is dismantled, the gas housing gasket will have to be renewed.
- 17 Place the burner insert in a safe place.
- ▷ Depending on the amount of dirt or wear: replace the ignition/ionization electrode rod and dowel pin during servicing – see page 10 (Checking the ignition and ionization electrodes).
- 18 Check burner head for dirt and thermal cracks.

⚠ WARNING

Risk of injury! Burner heads have sharp edges.

- ▷ When replacing any burner components: apply ceramic paste to the screw connections in order to avoid cold-setting – see page 12 (Ceramic paste).

19 Check the electrode positions.

- ▷ The insulator must be flush with the front edge of the burner air disc.

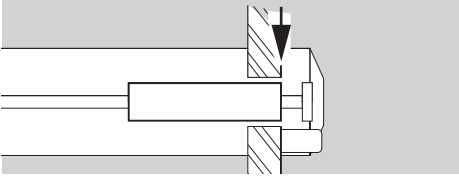

- ▷ Distance of ignition electrode from ground pin or gas nozzle: $2 \pm 0.5 \text{ mm}$ ($0.08 \pm 0.02''$).

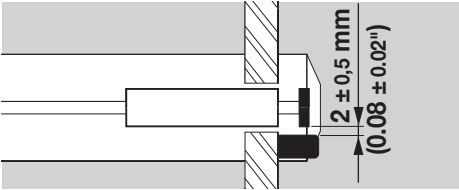

- 20** When the furnace chamber has cooled down, check the ceramic tube through the furnace flange.

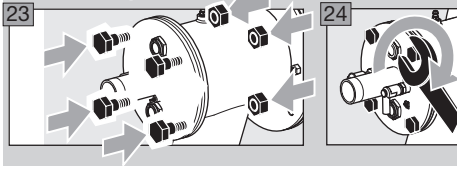
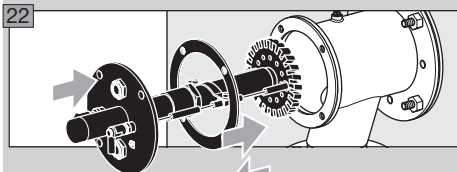
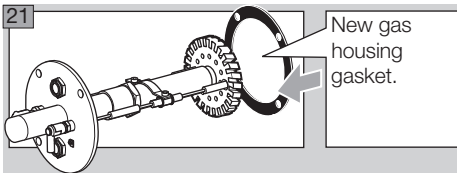

- ▷ Tighten the burner insert with max. 37 Nm (27.3 lb ft).

25 Connect the system to the electrical power supply.

26 Open the gas and air supply.

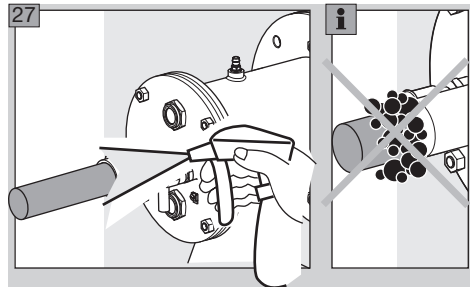

- 28** Set the burner to low fire and compare the pressure settings to those stated in the acceptance report.

- 29** Set the burner to low and high fire several times while monitoring the pressure settings, flue gas values and flame patterns.

⚠ DANGER

Risk of explosion and poisoning during burner adjustment with an air deficiency! Adjust the gas and air supply so that the burner is always operated with excess air – otherwise CO will form in the furnace chamber. CO is odourless and poisonous! Conduct a flue gas analysis.

- 30** Produce a maintenance report.

Assistance in the event of malfunction

⚠ DANGER

Electric shocks can be fatal! Before working on possible live components, ensure the unit is disconnected from the power supply.

Risk of injury! Burner heads have sharp edges. Fault-clearance must only be undertaken by authorized trained personnel.

- ▷ If no fault is detected when checking the burner, proceed to the automatic burner control unit and check for faults in accordance with the relevant operating instructions.

? **Faults**

! **Cause**

• **Remedy**

? **Burner does not function?**

! Valves do not open.

- Check the voltage supply and wiring.

! Tightness control signals a fault.

- Check the valves for tightness.
- Note the tightness control operating instructions.

! Control valves do not move to low-fire position.

- Check the impulse lines.

! Gas inlet pressure is too low.

- Check the filter for dirt.

! Gas and air pressures on the burner are too low.

- Check the restrictors.

! Automatic burner control unit signals a fault.

- Check the ionization cables and ionization current.
- Check whether the burner is adequately grounded.
- Note the automatic burner control unit operating instructions.

? **Burner performs a fault lock-out after burning faultlessly in normal operation?**

! Incorrect gas and air flow rate settings.

- Check the gas and air pressures.

! No ignition spark is created.

- Check the ignition cable.
- Check the voltage supply and wiring.
- Check whether the burner is adequately grounded.
- Check the electrodes – see page 10 (Checking the ignition and ionization electrodes).

! Automatic burner control unit signals a fault.

- Check the ionization cable.
- Measure the ionization current by connecting a micro-ammeter into the ionization cable: min. 5 μA ionization current – stable signal.

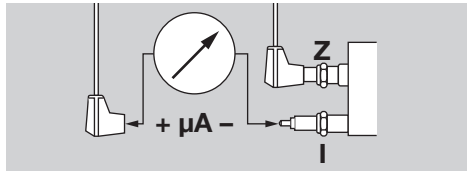

! Burner head dirty.

- Clean gas and air bore holes and air slots.
- Remove deposits on the burner head.

⚠ WARNING

Risk of injury! Burner heads have sharp edges.

! Excessive pressure fluctuations in the furnace chamber.

- Ask Elster Kromschroder for control concepts.

Accessories

Ceramic paste

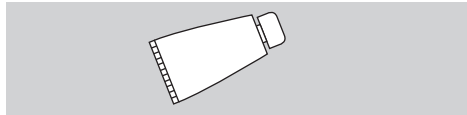

Apply ceramic paste to the relevant screw connections after replacing any burner components in order to avoid cold-setting.

Order number: 05012009.

Adapter set

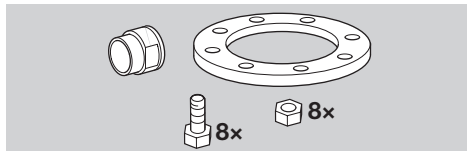

For connecting ZIC to NPT/ANSI connections.

Burner	Adapter set	Order No.
ZIC 165	BR 165 NPT	74922636
ZIC 200	BR 200 NPT	74922637

Nozzle set

- ▷ Available on request for connecting integrated ignition lances to NPT threads.

Technical data

Gas supply pressure: approx. 20 to 50 mbar,
air supply pressure: approx. 25 to 40 mbar,
each depending on flame shape, gas type and air
temperature (gas and air pressures – see operating
characteristic diagrams at www.docuthek.com).

Burner length increments: 100 mm.

Gas types: natural gas, LPG (gaseous) and coke
oven gas; other gases on request.

Control type:

staged: On/Off, High/Low/Off,

continuous: constant λ value.

Most of the burner components are made of corro-
sion-resistant stainless steel.

Housing:

ZIC: St.

Flame control: with ionization electrode (UV sensor
as an option).

Ignition: direct spark ignition; ignition lance as an
option.

Maximum furnace temperature:

up to 1450°C (higher temperatures on request).

Maximum air temperature:

ZIC: 450°C,

ZICW: 500°C.

Storage temperature: -20°C to +40°C.

Burner	Weight* [kg]
ZIC 165	23
ZIC 200	34.6

* Shortest overall length.

WARNING

applies to ZICW only

Information pursuant to REACH Regulation No.
1907/2006, Article 33. Insulation contains refrac-
tory ceramic fibres (RCF)/aluminium silicate wool
(ASW). RCF/ASW are listed in the Candidate List of
the European REACH Regulation No. 1907/2006.

Logistics

Transport

Protect the unit from external forces (blows, shocks,
vibration). On receipt of the product, check that the
delivery is complete, see page 2 (Part designa-
tions). Report any transport damage immediately.

Storage

Store the product in a dry and clean place.

Storage temperature: see page 13 (Technical data).

Storage time: 2 years before using for the first time.

If stored for longer than this, the overall service life
will be reduced accordingly (by the corresponding
amount of extra storage time).

Packaging

The packaging material is to be disposed of in ac-
cordance with local regulations.

Disposal

Components are to be disposed of separately in
accordance with local regulations.

Declaration of Incorporation



according to 2006/42/EC, Annex II, No. 1B
The product ZIC is a partly completed machine pursuant to Article 2g and is designed exclusively for installation in or assembly with another machine or other equipment.

The following essential health and safety requirements in accordance with Annex I of this Directive are applicable and have been fulfilled:

Annex I, Articles 1.1.3, 1.1.5, 1.3.2, 1.3.4, 1.5.2, 1.7.4
The relevant technical documentation has been compiled in accordance with part B of Annex VII and will be sent to the relevant national authorities on request as a digital file.

The following (harmonized) standards have been applied:

- EN 746-2 (2010) – Industrial thermoprocessing equipment; Safety requirements for combustion and fuel handling systems
- EN ISO 12100 (2010) – Safety of machinery – General principles for design – Risk assessment and risk reduction (ISO 12100:2010)

The partly completed machine may only be commissioned once it has been established that the machine into which the product mentioned above is to be incorporated complies with the provisions of the Machinery Directive 2006/42/EC.

Elster GmbH

Einbauerklärung
nach 2006/42/EG, Anhang II, Nr. 1B
Folgendes Produkt / The following product:
Bezeichnung: Brenner für Gas
Description: Burner for gas
Typenbezeichnung / Type: B9, B9A, Z9, B9C, B9CA, Z9C
B9W, Z9W, B9CW, Z9CW

/Declaration of Incorporation
/ according to 2006/42/EC, Annex II No. 1B

ist eine unvollständige Maschine nach Artikel 2g und ausschließlich zum Einbau in oder zum Zusammenbau mit einer anderen Maschine oder Ausrüstung vorgesehen.
is a partly completed machine pursuant to Article 2g and is designed exclusively for installation in or assembly with another machine or other equipment.

Folgende grundlegende Sicherheits- und Gesundheitschutzanforderungen gemäß Anhang I dieser Richtlinie kommen zur Anwendung und wurden eingehalten.
The following essential health and safety requirements in accordance with Annex I of this Directive are applicable and have been fulfilled:

Anhang I, Artikel / Annex I, Article
1.1.3, 1.1.5, 1.3.2, 1.3.4, 1.5.2, 1.7.4

Die speziellen technischen Unterlagen gemäß Anhang VII B wurden erstellt und werden über zuständige nationalen Behörden auf Verlangen in elektronischer Form überreicht.
The relevant technical documentation has been compiled in accordance with part B of Annex VII and will be sent to the relevant national authorities on request as a digital file.

Folgende (harmonisierte) Normen wurden angewandt: / The following (harmonized) standards have been applied:
EN 746-2(2010) – Industrielle Thermoprocessinganlagen; Sicherheitsanforderungen an Feuerungen und Brennstoffhandlungssysteme
– Industrial thermoprocessing equipment; Safety requirements for combustion and fuel handling systems
EN ISO 12100(2010) – Sicherheit von Maschinen – Allgemeine Gestaltungsgrundsätze – Risikobewertung
und Risikoreduzierung (ISO 12100:2010)
– Safety of machinery – General principles for design – Risk assessment
and risk reduction (ISO 12100:2010)

Die unvollständige Maschine darf erst dann in Betrieb genommen werden, wenn festgestellt wurde, dass die Maschine, in der das oben beschriebene Produkt eingebaut werden soll, den Bestimmungen der Richtlinie für Maschinen (2006/42/EG) entspricht.
The partly completed machine may only be commissioned once it has been established that the machine into which the product mentioned above should be incorporated complies with the provisions of the Machinery Directive 2006/42/EC.

Lotte (Büren)
31.03.2014
Datum / Date

Sandra Runde
Konstruktions- / Designer

Elster GmbH
Postfach 28 09
D-49018 Osnabrück
Strothweg
D-49504 Lotte (Büren)
Tel. +49 (0)541 12 14-0
Fax +49 (0)541 12 14-20
www.kromschroeder.com

Sandra Runde ist bevollmächtigt, die speziellen technischen Unterlagen gemäß Anhang VII B zusammenzustellen.
Sandra Runde is authorized to compile the relevant technical documentation according to Annex VII B.

Certification

Approval for Russia



Certified by Gosstandart under Technical Regulations.
Approved by Rostekhnadzor (RTN).

Contact

If you have any technical questions, please contact your local branch office/agent. The addresses are available on the Internet or from Elster GmbH.

We reserve the right to make technical modifications in the interests of progress.

elster
Kromschroder

Elster GmbH
Postfach 28 09, D-49018 Osnabrück
Strothweg 1, D-49504 Lotte (Büren)
T +49 541 1214-0
F +49 541 1214-370
info@kromschroeder.com, www.kromschroeder.com