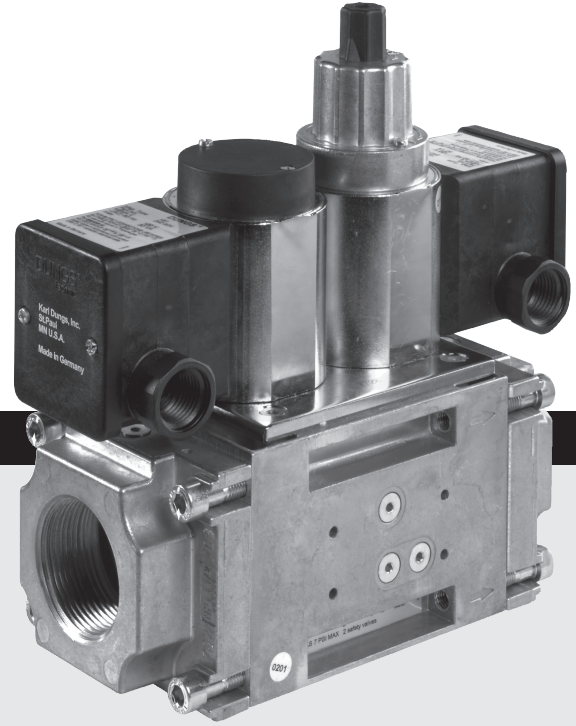

Table of Contents

Table of Contents	Page 1	Accessories & Replacement	Page 9
Approvals	Page 1		
Attention	Page 1		
Specification	Page 2		
Mounting	Page 3		
Painting Valve	Page 4		
Protection from Radiant Heat	Page 4		
Positioning Junction Boxes	Page 4		
Wiring	Page 5		
Valve Adjustment	Page 5		
Test Ports	Page 6		
Rated Capacity	Page 6		
Valve Leakage Test	Page 7		
Flow Curve	Page 8		
Pressure Drop for other Gases	Page 8		



Approvals



UL Listed:
 File No. MH16727



CSA Certified:
 File No. 1010989



FM Approved:
 File No. J.I.1Z6A0.AF

Commonwealth of Massachusetts Approved Product Approval code G1-1107-35

Attention



The installation and maintenance of this product must be done under the supervision of an experienced and trained specialist. Never perform work if gas pressure or power is applied, or in the presence of an open flame.

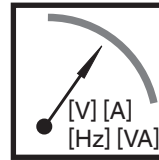

Check the ratings in the specifications to make sure that they are suitable for your application.



Please read the instruction before installing or operating. Keep the instruction in a safe place. You find the instruction also at www.dungs.com If these instructions are not heeded, the result may be personal injury or damage to property.



On completion of work on the safety valve, perform a leakage and function test.



Any adjustment and application-specific adjustment values must be made in accordance with the appliance-/boiler manufacturers instructions.



This product is intended for installations covered by, but not limited to, the following fuel gas codes and standards: NFPA 54; IFGC (International Fuel Gas Code) or CSA B149.1 (for Canada) or the following equipment codes and standards: CSD-1, UL 795, NFPA 86, NFPA 37, ANSI Z83.4/CSA 3.7, ANSI Z83.18, ANSI Z21.13/CSA 4.9 or CSA B149.3 (for Canada).

Explanation of symbols

- 1, 2, 3 ... = Action
- = Instruction

Specification

DMV-D/604L Two normally closed safety shutoff valves in one housing. V1 and V2 are fast opening, fast closing. Two stage and adjustable max. flow on V2. NEMA Type 4x.

DMV-DLE/604L Two normally closed safety shutoff valves in one housing. V1 fast opening, fast closing. V2 is a slow opening, fast closing valve. Adjustable max. flow and adjustable initial lift with V2. NEMA Type 4x.

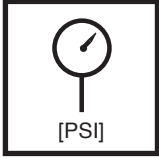

Max. Operating Pressure
MOP = 7 PSI (500 mbar) UL, FM
MOP = 5 PSI (350 mbar) CSA

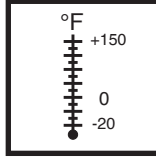

Ambient Temperature
-20 °F ... +150 °F
(-30 °C ... +65 °C)



Electrical Ratings
110 - 120 VAC / 50 - 60 Hz;
Operating time
100 % duty cycle
Power Consumption with all coils energized
DMV-D(LE) 702: 60 VA
DMV-D(LE) 703: 80 VA

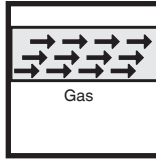

Gases
Dry, natural gas, propane, butane; other noncorrosive gases. A "dry" gas has a dew point lower than +15 °F and its relative humidity is less than 60 %.
Materials in contact with Gas
Housing: Aluminium, Steel, free of nonferrous metals.
Sealings on valve seats: NBR-based rubber.

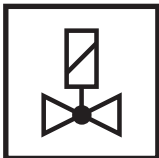

Classification of Valve V1 and V2 Safety Shutoff Valve: UL 429, FM 7400 & ANSI Z21.21
• CSA 6.5 C/I Valves
Closing Time (Valve 1 & Valve 2)
< 1 s
Opening Time
DMV-D/624: V1 & V2 < 1 s
DMV-DLE/624: V1 < 1 s;
V2 10 to 20 s at 70 °F
Max. Flow Setting (DMV-D/624L & DMV-DLE/624L)
Adjustable on V2:
<10 to 100 % of total flow
Initial Lift Adjustment (DMV-DLE/624L)
Adjustable on V2:
0 to 70 % of total flow, 0 to 25 % of stroke

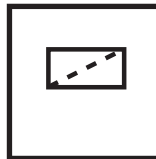

Strainer
23 Mesh, installed in the housing upstream V1

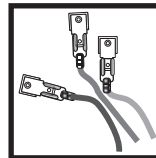

Electrical Connection
Terminal boxes with NPT 1/2" conduit connections

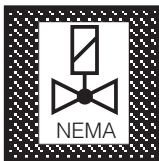

Enclosure Ratings Available
NEMA Type 4x

Alterations, Modifications or Repairs

For safety-related components, devices and systems, any liability of DUNGS, i.e. product liability for any kind of consequential damage as well as liability for defects, will cease to exist if alterations, modifications or repairs are made to these safety-related components, devices and systems by unauthorized specialist staff or with spare parts which have not been specially permitted for use in these safety-related components, devices and systems.

Mounting

Setup

1. Examine the DMV-D(LE)/604L for shipping damage.
2. The main gas supply must be shutoff before starting the installation.
3. The inside of the DMV-D(LE)/604L, the flanges, and piping must be clean and free of dirt, remove all dirt and debris before installing the DMV-D(LE)/604L. Failure to remove dirt / debris could result in valve damage or improper performance.

Recommended Procedure to Mount the Flanges

1. Unpack the DMV valve and remove the socket cap head screws. Using a 6 mm hex wrench
2. Remove the two white protective plastic covers.
3. Verify the o-rings and the grooves are clean and in good condition.
4. Install the DMV valve with the gas flow matching the direction indicated by the arrows on the casting.
5. Mount the DMV solenoid valve from vertically upright to horizontal.
6. Clean the mounting surface of the flanges.
7. Mount the flanges with the test port in the position relative to the coil as shown in the figure. Failure to have the test port in the correct position may cause a gas leak.
8. Tighten the screws in a crisscross pattern. See table for recommended torque!

Installation position

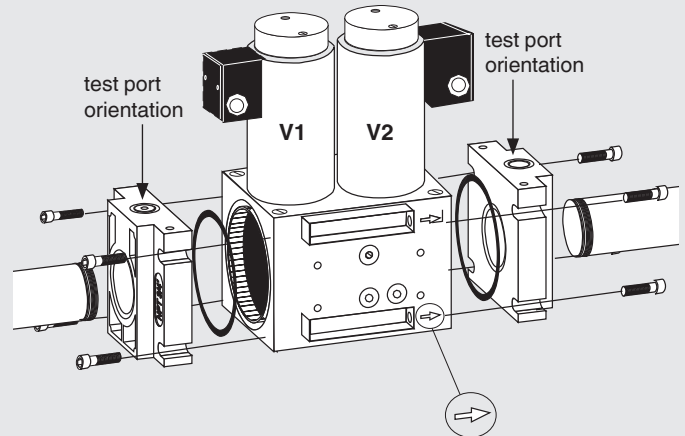
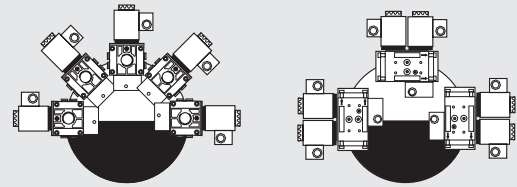

Do not overtighten the screws. Follow the maximum torque values below.



If the flow is not in the same direction of the arrows, the valves will not operate properly.

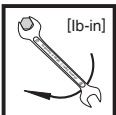

Recommended Torque System Accessories

M6	M8	Screw Size
62 lb-in	134 lb-in	[lb-in]

Recommended Piping Procedure

- Use new, properly reamed and threaded pipe free of chips.
- Apply good quality pipe sealant, putting a moderate amount on the male threads only. If pipe sealant lodges on the valve seat, it will prevent proper operation. If using LP gas, use pipe sealant rated for use with LP gas.

- Do not thread pipe too far. Valve distortion and/or malfunction may result from excess pipe in the valve body.
- Apply counter pressure only a parallel jaw wrench only to the flats on the flange when connecting to pipe.
- Do not overtighten the pipe. Follow the maximum torque values listed below.

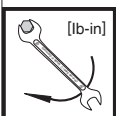

Recommended Torque for Piping

1"	1 1/4"	1 1/2"	2"	NPT pipe
750	875	940	1190	[lb-in]

• On completion of work on the DMV valve, perform a leakage test. (See "Valve Leakage Test")

Positioning junction boxes

- Locate the black knob on top of Valve 1. There are two screws, the holding screw is recessed and has a blue sealing compound on it, while the pan head screw protrudes from the cap.
- Remove both screws, remove the black knob, remove the slotted washer.
- Remove the coil assembly Valve 1 ONLY .
- Locate the black knob on top of Valve 2. There are two screws, the holding screw is recessed and has a blue sealing compound on it, while the pan head screw protrudes from the cap.

- Loosen the pan head screw until you can freely rotate the coil assembly. Position the coil so that the junction box is in an accessible location to connect to conduit.
- Replace the coil from Valve 1. Position the coil so that the junction box is in an accessible location to connect to conduit.
- Re-install the washer, black cap, and the screws.

Painting Valve

- It is not recommended that this valve be painted. Painting covers date codes and other labels that identify this valve.
- If the valve needs to be painted, a paint free of volatile organic components (VOC's) must be used. VOC's can damage valve o-rings, resulting in external gas leakage over time.
- During the painting process, use measures that will allow the valve's date code and other labeling information to be legible after the paint is dry.

Protection from Radiant Heat

- Radiant heat must be considered as a heat source that could result in an ambient temperature higher than the rating of this valve.
- Provide proper shielding to protect against radiant heat.

Positioning Junction Boxes

1. Locate the black knob on top of Valve 1. There are two screws, the holding screw is recessed and has a blue sealing compound on it, while the pan head screw protrudes from the cap,
2. Remove both screws, remove the black knob, remove the slotted washer.
3. Remove the coil assembly Valve 1 ONLY.
4. Locate the black knob on top of Valve 2. There are two screws, the holding screw is recessed and has a blue sealing compound on it, while the pan head screw protrudes from the cap.
5. Loosen the pan head screw until you can freely rotate the coil assembly. Position the coil so that the junction box is in an accessible location to connect to conduit.
6. Replace the coil from Valve 1. Position the coil so that the junction box is in an accessible location to connect to conduit
7. Re-install the washer, black cap and the screw.

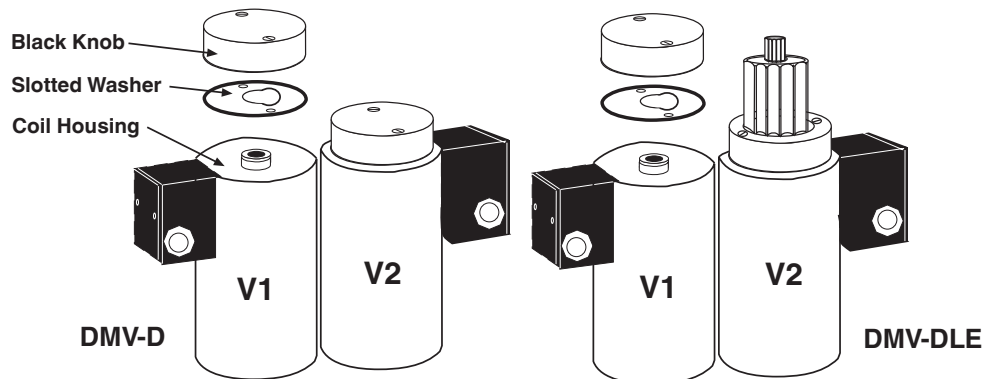

⚠ Do not adjust or remove any screws or bolts which are sealed with a Red colored compound. Doing so will void all approvals and warranties.

⚠ Do not remove the adjustment cap from valve 2. If the adjustment cap is removed, perform the valve leakage test on page 5 - with special attention to the area under the adjustment cap.

Wiring

- 1) Remove the junction box cover to expose the three terminals
- 2) The coil can be rotated to accommodate a conduit connection in any position.
- 3) Use only one of the knock-outs for connecting conduit to the junction box. Support the opposite side of the junction box when removing the knock-out.

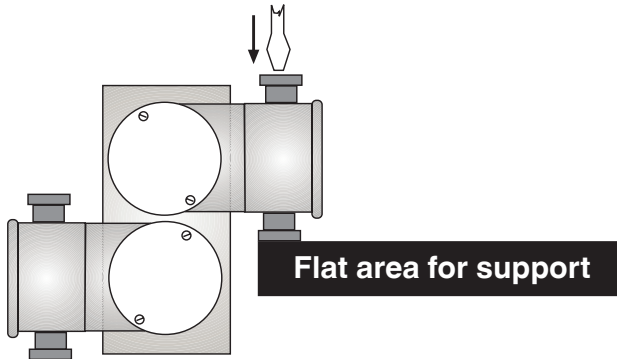

- 4) Run 14 or 16 gauge wire rated for 95 °C (200 °F) through the conduit and attach 1/2" NPT conduit to the junction box.

- 5) Use appropriate tools to connect the conduit fitting to the junction box.
- 6) Make electrical connections to the terminals using the wiring diagram.

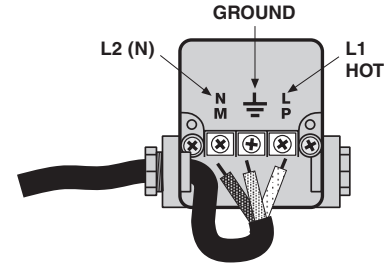

- 7) Replace junction box cover.



All wiring must comply with local electrical codes, ordinances and regulations.

Valve Adjustment

Flow Setting

- The valves are factory set with the flow adjustment fully open.
- Locate the appropriate knob on top of **Valve 2**. There are two screws, the holding screw is recessed and has a blue sealing compound on it, while the pan head screw protrudes from the cap.
- Loosen the pan head screw until you can freely rotate the flow adjustment.
- Turn clockwise for less gas or counterclockwise for more gas.
- Check the flow at the burner with an orifice or flow meter.
- Tighten the pan head screw on the adjustment cap.

Initial Lift Adjustment (DMV-DLE only)

The initial lift adjustment varies the initial gas flow through the valve as the valve seat begins to open. This adjustment can vary the initial flow between 0 % and 70 % of the total gas flow; 0 to 25 % of stroke. All DMV-DLE valves are factory set with minimum initial lift. To adjust the lift proceed as follows:

- Unscrew the small black cap on top of the flow adjustment cap to expose the initial lift adjustment knob.
- The black cap also serves as tool; turn the cap over and insert it on the slot on the adjustment knob.
- Turn the knob clockwise for a min initial lift or counterclockwise for a max. initial lift.
- Once the desired initial lift has been achieved, reinstall the black cap.

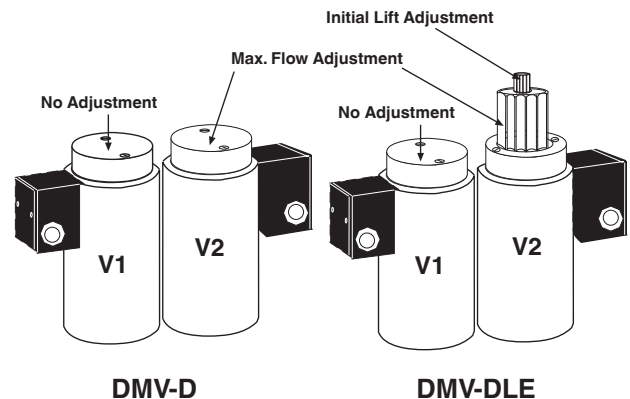

Test Ports

Test Ports

The G 1/8 ISO 228 taps are available on both sides upstream V1, between V1 and V2, downstream V2, and on both flanges. The G 1/8 test nipple (P/N 219008) can be screwed in any of these pressure tap ports.

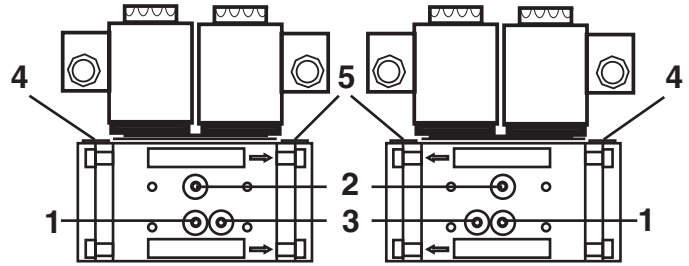
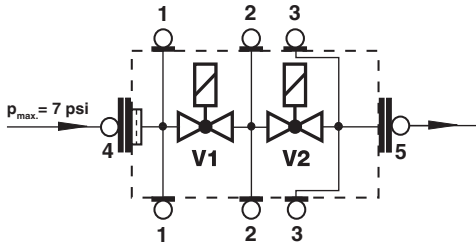

Rated Capacity

Capacity in CFH at pressure drop of 1 inch water column; natural gas, sp.gr.= 0.64

	1/2"	3/4"	1"	1 1/4"	1 1/2"	2"
DMV-D(LE) 702/602	-	-	1065	1277	1368	1430
DMV-D(LE) 703/602	-	-	1230	1532	1698	1795

Valve Leakage Test

This leak test procedure tests the external sealing and valve seat sealing capabilities of the DMV automatic safety shutoff valve. Only qualified personnel should perform this test.

It is required that this test be done on the initial system startup, and then repeated at least annually. Possibly more often depending on the application, environmental parameters, and the requirements of the authority having jurisdiction.

Setup

This test requires the following:

- Test nipples installed in the downstream pressure tap port of each automatic safety shutoff valve to make the required 1/4" hose connection in step 4.
- A transparent glass of water filled at least 1 inch from the bottom.
- A proper leak test tube. An aluminum or copper 1/4" rigid tube with a 45° cut at the end that is then connected to a 1/4" flexible hose of some convenient length provides for a more accurate leakage measurement. However, a 45° cut at the end of the 1/4" flexible hose will suffice, but it will not likely be as accurate as the rigid tube.
- For detecting external leakages, an all purpose liquid leak detector solution or a soapy water solution is required.

Leak Test Procedure

Use the illustration below as a reference.

- With the upstream ball valve open, the downstream ball valve closed and both valves energized, apply an all purpose liquid leak detector solution to the "External Leakage Test Areas" indicated in the illustration below, to any accessories mounted to the safety valve, and to all gas piping and gas components downstream the equipment isolation valve, and the inlet and outlet gas piping of the automatic safety shutoff valve. The presence of bubbles

indicates a leak, which needs to be rectified before proceeding.

- Then, de-energize the burner system and verify that both automatic safety shutoff valves are closed.
- Close the upstream and downstream manual ball valve.
- Using a screwdriver, slowly open the V1 test nipple (port 2) by turning it counter clockwise to depressurize the volume between the two valves, and connect the 1/4" flexible hose to the test nipple.
- Slowly open the upstream manual ball valve, and then provide for some time to allow potential leakage to charge the test chamber before measuring the valve seat leakage.
- Immerse the 1/4 in. tube vertically 1/2 in. (12.7 mm) below the water surface. If bubbles emerge from the 1/4" tube and after the leakage rate has stabilized, count the number of bubbles appearing during a 10 second period. (See chart below for allowable leakage rates.)
- Repeat the same procedure for valve V2 (port 3).
(Energize terminal 2 on the DIN connector to open valve 1)

After completing the above tests proceed as follows:

- Verify that the downstream manual ball valve is closed, and both automatic safety shutoff valves are de-energized.
- Remove the flexible hose, and close all test nipples.
- With the upstream manual ball valve open, energize both automatic safety shutoff valves.
- Use soapy water to leak test all test nipples to ensure that there are no leaks.
- If no leakage is detected, de-energize all automatic safety shutoff valves, and open the downstream manual ball valve.



If leakage values are exceeded, replace valve immediately.

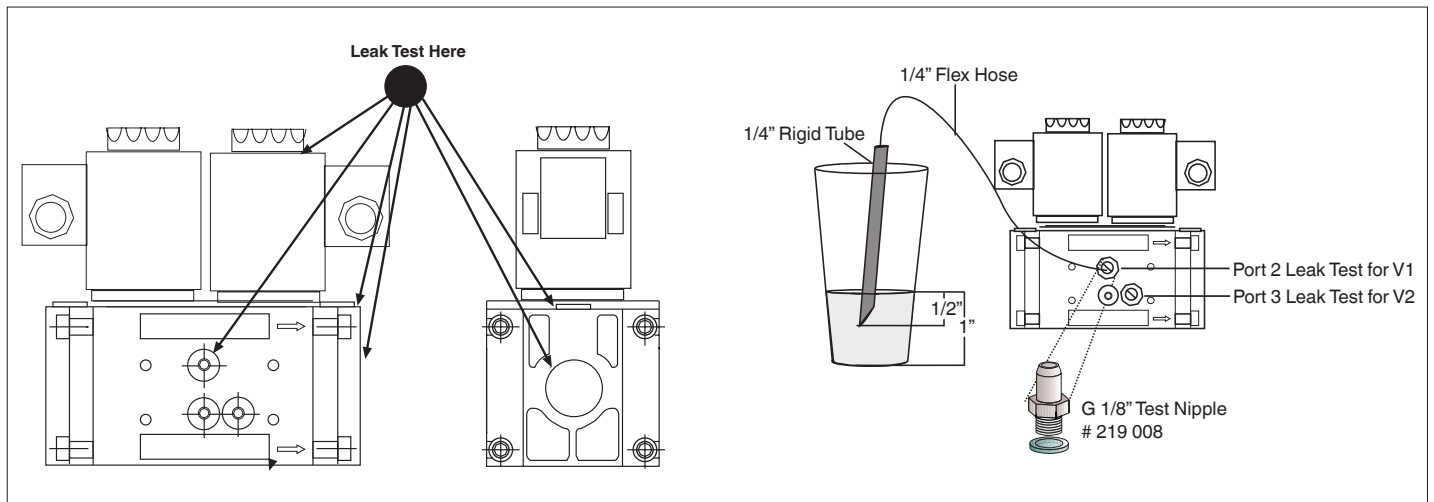

Type	Allowable Valve Seat Leakage* up to 7 PSI inlet	# of Bubbles in 10 s		
		Air	Natural Gas	LP
DMV-D(LE) 702/604L	464 cc/hr	9	11	7
DMV-D(LE) 703/604L	464 cc/hr	9	11	7

*Based on air and test conditions per UL 429 Section 29. (Air or inert gas at a pressure of 1/4 psig and also at a pressure of one and one-half times maximum operating pressure differential, but not less than 1/2 psig. This test shall be applied with the valve installed in its intended position.)
Volume of bubble defined in Table 2 of FCI 70-2-1998.

Flow Curve

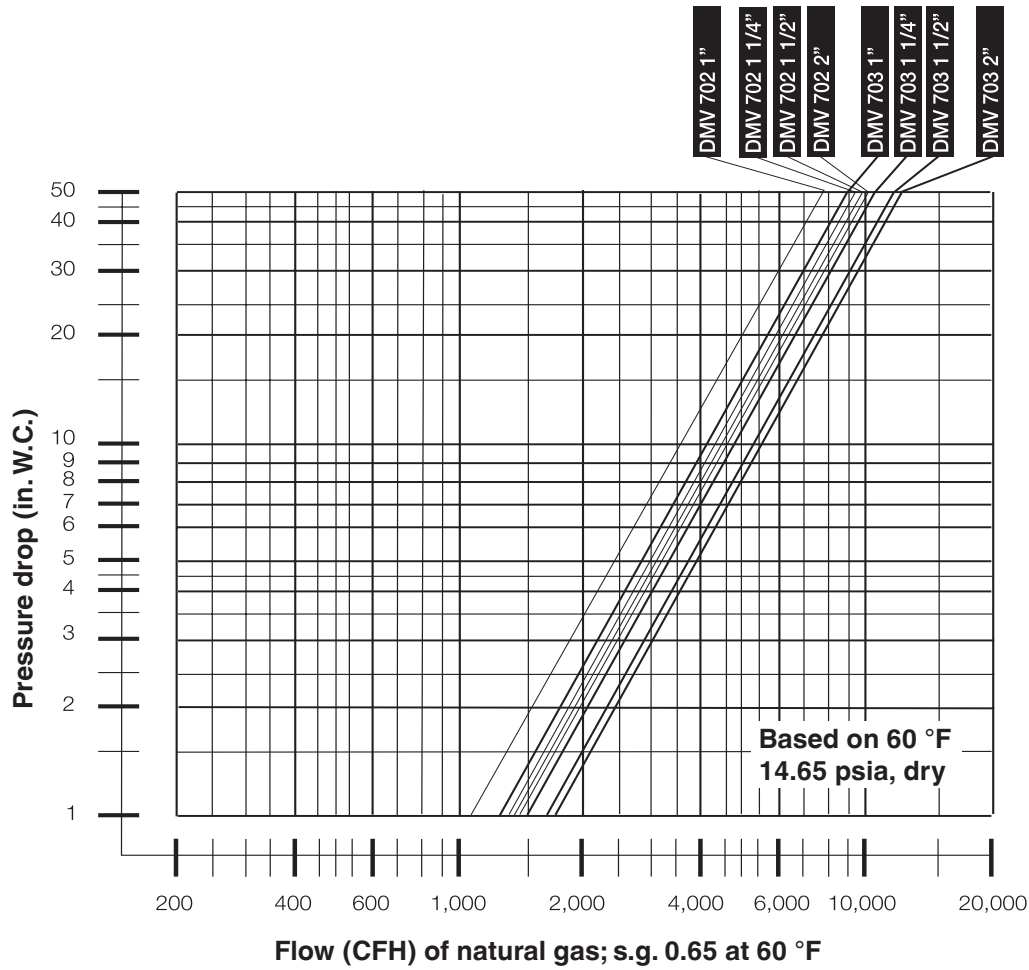

Pressure Drop for other Gases

To determine the pressure drop when using a gas other than natural gas, use the flow formula below and f value located in the table below to determine the “corrected” flow rate in CFH through the valve for the other gas used. For example,

when using propane, divide the volume (CFH) of propane required for the application by the calculated value f (f = 0.66 for propane). Use this “corrected” flow rate and the flow curve on the next page to determine pressure drop for propane.

Determining equivalent flow through valves using another gas

$$\dot{V}_{\text{gas used}} = \dot{V}_{\text{Natural gas}} \times f$$

$$f = \sqrt{\frac{\text{Density of Natural gas}}{\text{Density of gas used}}}$$

Type of gas	Density [kg/m ³]	s.g.	f
Natural gas	0.81	0.65	1.00
Butane	2.39	1.95	0.58
Propane	1.86	1.50	0.66
Air	1.24	1.00	0.80

Accessories & Replacement		
Coil for	Magnet Type	Order No. for 120 VAC*
DMV-D(LE) 702/604L	151	246515
DMV-D(LE) 703/604L	152	246516
*Includes only one coil for one valve. If both coils need replacing, then order two of the above mentioned parts.		
Accessories/Adapter	Order No.	
Visual Indicator	266949	The indicator mounts to the bottom of the valve and visually displays when the valve is open or closed.
Valve Switch CPI 400	266968	Valve switch with visual indication.
1/4" NPT port 1, port 2, or flange adapter (reduced port)	225047	
1/2" NPT port 2 pilot / vent adapter (reduced port)	225043	
G 1/8" Test nipple with gasket	219008	
Gasket for G1/8" test nipple	171260	
Port 3 Pressure switch mounting adapter	273777	
Hydraulic Brake	224457	
Max. Flow Adj. Knob	240457	

Valve Description	Flange Size	NPT Order No.	Rp Order No.	O-ring and bolt kit for flanges Order No.*
DMV-702 & 703	1"	222369	222343	224094
DMV-702 & 703	1 1/4"	222370	222344	224094
DMV-702 & 703	1 1/2"	222003	221884	224094
DMV-702 & 703	2"	221997	221926	224094
*Includes two o-rings and two sets of bolts (one set of four bolts for each flange).				

We reserve the right to make modifications in the course of technical development.