

03251389

**krom
schroder**

D GB F NL I E DK S N P GR
TR CZ PL RUS H → www.docuthek.com

Operating instructions

Solenoid valve for gas

VG 6 – VG 15/10



Contents

Solenoid valve for gas	
VG 6 – VG 15/10	1
Contents	1
Safety	1
Checking the usage	2
Intended use	2
Type code	2
Part designations	2
Type label	2
Installation	2
Wiring	2
Tightness test	3
Replacing the solenoid actuator	4
Maintenance	4
Assistance in the event of malfunction	5
Technical data	5
Logistics	6
Disposal	6
Certification	6
Declaration of conformity	6
Approval for Australia	6
Eurasian Customs Union	6
Contact	6

Safety

Please read and keep in a safe place



Please read through these instructions carefully before installing or operating. Following the installation, pass the instructions on to the operator. This unit must be installed and commissioned in accordance with the regulations and standards in force. These instructions can also be found at www.docuthek.com.

Explanation of symbols

■, **1**, **2**, **3**... = Action

> = Instruction

Liability

We will not be held liable for damage resulting from non-observance of the instructions and non-compliant use.

Safety instructions

Information that is relevant for safety is indicated in the instructions as follows:

⚠ DANGER

Indicates potentially fatal situations.

⚠ WARNING

Indicates possible danger to life and limb.

! CAUTION

Indicates possible material damage.

All interventions may only be carried out by qualified gas technicians. Electrical interventions may only be carried out by qualified electricians.

Conversion, spare parts

All technical changes are prohibited. Only use OEM spare parts.

Changes to edition 04.19

The following chapters have been changed:

- Certification
- Disposal

Checking the usage

Intended use

Gas solenoid valve for safeguarding gas or air on various appliances.

This function is only guaranteed when used within the specified limits – see page 5 (Technical data).

Any other use is considered as non-compliant.

Type code

Code	Description
VG	Gas solenoid valve
6-15/10	Nominal size
K	Double-cone olive for 8 mm tube loosely enclosed
R	Rp internal thread
01	$p_{U \text{ max.}}$ 100 mbar
03	$p_{U \text{ max.}}$ 360 mbar
05	$p_{U \text{ max.}}$ 500 mbar
18	$p_{U \text{ max.}}$ 1.8 bar
T	Mains voltage: 220/240 V AC, 50/60 Hz
Q	Mains voltage: 120 V AC, 50/60 Hz
K	Mains voltage: 24 V DC
6	Connection via 3-pin standard plug and socket
G	Low-noise

Part designations

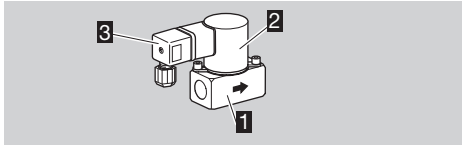

- 1** Housing
- 2** Solenoid actuator
- 3** Socket

Type label

Rated voltage, electrical power consumption, installation position, max. inlet pressure p_U , ambient temperature, enclosure and medium: see type label.

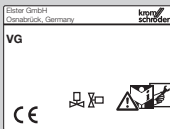

Installation

! CAUTION

Please observe the following to ensure that the VG is not damaged during installation and operation:

- Do not install or store the unit in the open air.
 - Dropping the device can cause permanent damage. In this event, replace the entire device and associated modules before use.
 - Check max. ambient temperature and max. inlet pressure – see type label.
- ▷ Installation position: black solenoid actuator in the vertical upright position or tilted up to the horizontal, not upside down.
 - ▷ Sealing material and dirt, e.g. thread cuttings, must not be allowed to get into the valve housing.
 - ▷ Install a filter upstream of every system.
 - ▷ Use approved sealing material only.
 - ▷ Ensure that there is sufficient space for installation and adjustment.

VG 6K for compression fittings

- ▷ The double-cone olive and cap screw are enclosed.

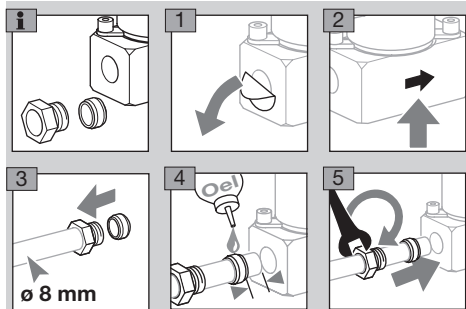

Wiring

⚠ WARNING

Attention! Please observe the following to ensure that no damage occurs:

- Electric shocks can be fatal! Before working on possible live components, ensure the unit is disconnected from the power supply.
- The solenoid actuator heats up during operation. Surface temperature approx. 85°C (approx. 185°F).



- ▷ Use temperature-resistant cable (> 80°C/176°F).
- ▷ Wiring to EN 60204-1.
- 1** Disconnect the system from the electrical power supply.

Replacing the solenoid actuator

- ▷ We recommend replacing the entire actuator set when replacing the solenoid actuator.
- ▷ The actuator set is available separately as a spare part.

- 1** Disconnect the system from the electrical power supply.
- 2** Shut off the gas supply.

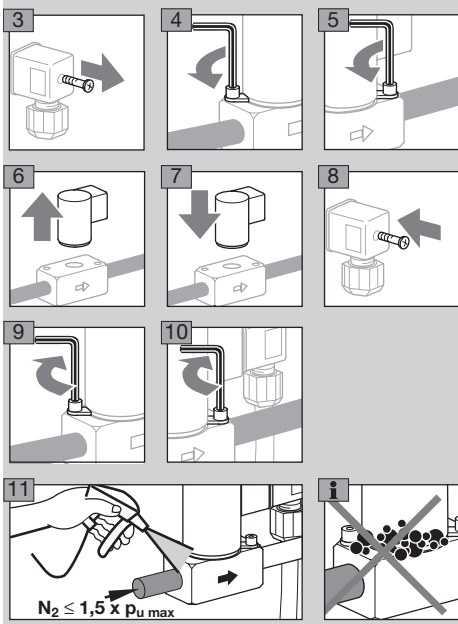

- 11** When the solenoid actuator is removed, the gas-filled space in the VG is opened. Therefore, check for internal tightness once the new actuator has been installed, see page 3 (Tightness test).
- 12** Tightness OK: release the gas supply.

Maintenance

! CAUTION

In order to ensure smooth operation: check the tightness and function of the VG every year, or every six months if operated with biogas.

- 1** Disconnect the system from the electrical power supply.
- 2** Shut off the gas supply.

Cleaning the strainer

- ▷ If the flow rate is correct, see page 3 (Tightness test).
- ▷ If the flow rate has dropped, clean the strainer.

VG 6-8

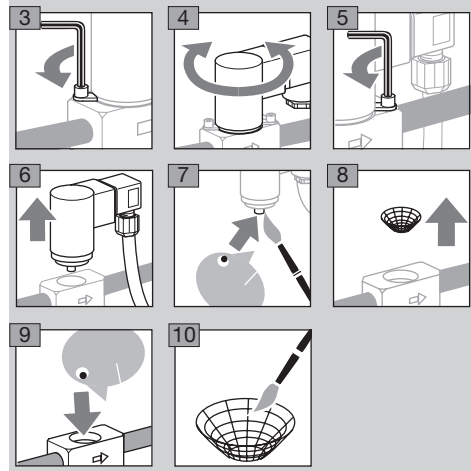

- 11** Follow the reverse procedure when reassembling.

VG 10-15/10

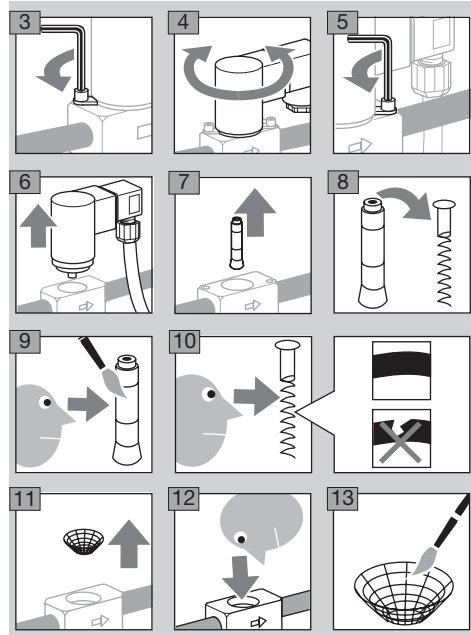

- 14** Follow the reverse procedure when reassembling.

Checking tightness and function

- ▷ When the solenoid actuator is removed, the gas-filled space in the VG is opened. Therefore, check for tightness once the actuator has been reinstalled.
- ▷ In order to determine whether the VG is tight and closes securely, check the internal and external tightness, see page 3 (Tightness test).
- ▷ Check electrical installations in line with local regulations; pay particular attention to the PE wire.

Assistance in the event of malfunction

⚠ WARNING

Electric shocks can be fatal! Before working on possible live components, ensure the unit is disconnected from the power supply. Fault-clearance must only be undertaken by authorized trained personnel. Unauthorized repairs or incorrect electrical connections can cause the solenoid valve to become defective. In this case, our warranty will be rendered void.

? Fault

! Cause

• Remedy

? The solenoid valve does not open, there is no flow downstream of the solenoid valve.

- ! There is no power supply.**
- Have wiring checked by authorized trained personnel.
- Remove the unit and return it to the manufacturer.

? The solenoid valve does not close securely, the flow downstream of the solenoid valve does not stop.

- ! Valve seat is dirty.**
- Clean the valve seat, see page 4 (Maintenance).
- Install a filter upstream of the solenoid valve.
- ! Valve seat is damaged.**
- Remove the unit and return it to the manufacturer.
- ! Valve seal is damaged or hardened.**
- Remove the unit and return it to the manufacturer.

Technical data

Ambient conditions

Icing, condensation and dew in and on the unit are not permitted.

Avoid direct sunlight or radiation from red-hot surfaces on the unit. Note the maximum medium and ambient temperatures!

Avoid corrosive influences, e.g. salty ambient air or SO₂.

The unit may only be stored/installed in enclosed rooms/buildings.

The unit is suitable for a maximum installation height of 2000 m AMSL.

Ambient temperature: -15 to +60°C (5 to 140°F). No condensation permitted.

Long-term use in the upper ambient temperature range accelerates the ageing of the elastomer materials and reduces the service life (please contact manufacturer).

Storage temperature: -20 to +40°C (68 to 104°F).

Transport temperature = ambient temperature.

Enclosure: IP 54.

This unit is not suitable for cleaning with a high-pressure cleaner and/or cleaning products.

Mechanical data

Gas types: natural gas, town gas, LPG (gaseous), biogas (max. 0.1 %-by-vol. H₂S) or clean air; other gases on request.

The gas must be dry in all temperature conditions and must not contain condensate.

Max. inlet pressure p₁: see type label.

Opening time: ≤ 1 s.

Closing time: ≤ 1 s.

Safety valve:

Class A, Group 2 pursuant to EN 161.

Valve housing: aluminium.

Valve disc: NBR.

Internal thread: Rp to ISO 7-1.

Air flow rate Q for pressure loss Δp = 1 mbar.

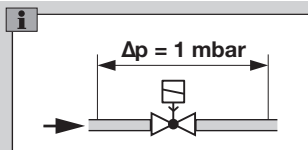

	Q [m ³ /h]
VG 6	0.45
VG 8R03G	0.60
VG 8R05	0.60
VG 8R18	0.25
VG 10R01	1.25
VG 15/10R01	1.35

Electrical data

Mains voltage:

220/240 V AC, +10/-15%, 50/60 Hz,

120 V AC, +10/-15%, 50/60 Hz,

24 V DC, +10/-15%.

Electrical connection:

plug with socket to EN 175301-803.

Duty cycle: 100%.

Power factor of the solenoid coil: cos φ = 1.

Power consumption:

Type	Voltage	Power
VG 6–15/10	24 V DC	8 W DC
	120 V AC	8 W DC
	230 V AC	9.5 W DC

Switching frequency: max. 30/min.

Designed lifetime

This information on the designed lifetime is based on using the product in accordance with these operating instructions. Once the designed lifetime has been reached, safety-relevant products must be replaced. Designed lifetime (based on date of manufacture) in accordance with EN 161 for VG:

Type	Designed lifetime	
	Switching cycles	Time [years]
VG 6 – VG 15/10	200,000	10

You can find further explanations in the applicable rules and regulations and on the afecor website (www.afecor.org).

This procedure applies to heating systems. For thermo-processing equipment, observe local regulations.

Logistics

Transport

Protect the unit from external forces (blows, shocks, vibration).

Transport temperature: see page 5 (Technical data).

Transport is subject to the ambient conditions described.

Report any transport damage on the unit or packaging without delay.

Check that the delivery is complete, see page 2 (Part designations).

Storage

Storage temperature: see page 5 (Technical data).

Storage is subject to the ambient conditions described.

Storage time: 6 months in the original packaging before using for the first time. If stored for longer than this, the overall service life will be reduced by the corresponding amount of extra storage time.

Disposal

Devices with electronic components:

WEEE Directive 2012/19/EU – Waste Electrical and Electronic Equipment Directive



At the end of the product life (number of operating cycles reached), dispose of the packaging and product in a corresponding recycling centre. Do not dispose of the unit with the usual domestic refuse. Do not burn the product. On request, old units may be returned carriage paid to the manufacturer in accordance with the relevant waste legislation requirements.

Certification

Declaration of conformity



Contact

If you have any technical questions, please contact your local branch office/agent. The addresses are available on the Internet or from Elster GmbH.

We reserve the right to make technical modifications in the interests of progress.

We, the manufacturer, hereby declare that the product VG with product ID No. CE-0063BL1553 complies with the requirements of the listed Directives and Standards.

Directives:

- 2014/35/EU – LVD
- 2014/30/EU – EMC
- 2011/65/EU – RoHS II
- 2015/863/EU – RoHS III

Regulation:

- (EU) 2016/426 – GAR

Standards:

- EN 161:2011+A3:2013

The relevant product corresponds to the tested type sample.

The production is subject to the surveillance procedure pursuant to Regulation (EU) 2016/426 Annex III paragraph 3.

Elster GmbH

Scan of the Declaration of conformity (D, GB) – see www.docuthek.com

Approval for Australia



Australian Gas Association, Approval No.: 3968
www.aga.asn.au/product_directory

Eurasian Customs Union



The product VG meets the technical specifications of the Eurasian Customs Union.

REACH Regulation

The device contains substances of very high concern which are listed in the Candidate List of the European REACH Regulation No. 1907/2006. See Reach list HTS at www.docuthek.com.

Honeywell

**krom/
schroder**

Elster GmbH
Strotheweg 1, D-49504 Lotte (Büren)
Tel. +49 541 1214-0
Fax +49 541 1214-370
hts.lotte@honeywell.com, www.kromschroeder.com