

V4730C/V8730C/V4734C

1:1 Gas/Air Servo Regulated Gas Valves

Product data



Note: Photo shows valve with manual safety shutoff valve and venturi installed.

CONTENTS

Application	1
Features	1
Specifications	2
Ordering Information.....	3
Installation	13
Electrical Connections	14
Adjustments and Final Checkout	14
Operation	15
Troubleshooting.....	16
Service Information	16

APPLICATION

The V4730C/V8730C/V4734C 1:1 Gas/Air Servo Regulated Gas Valves, with the addition of the Venturi Mixing Unit (VMU) and dc fan, are used for modulating premix appliances such as gas burners, gas boilers, rooftop units, makeup air units and process applications.

FEATURES

- Wide modulation range (14% to 100% of burner load).
- 24 Vac and 120 Vac models.
- Main valve body with two shutoff seats (double block valve).
- Closing time less than one second.
- Mesh screen (strainer) between inlet flange and main body.
- Various pressure tap points available at main body when no additional valves or pressure switches are used.
- DIN 43650 Plug Connector with 36-in. (914 mm) leadwires included.
- Flexible mounting positions of venturi manifold to fan.
- Replaceable pipe flange adapters available.
- Position indication lamp for each valve stage

SPECIFICATIONS

The specifications in this section are related to the Venturi Mixing Unit (VMU) and Combination Gas Valve.

Models: See Table 1

Table 1: Model Information

Model Number	Size (in.)	Voltage/Frequency	V1 + V2 Total Current	Capacity (Natural Gas 0.64sp.gr)
V4730C1006	1/2	120 Vac, 50/60 Hz	0.32 A	22-150 kW (73-512 kBtuh)
V4730C1014	3/4			43-300 kW (146-1024 kBtuh)
V4730C1022	1		0.5 A	55-382 kW (185-1300 kBtuh) ^a /71 - 500 kW (245-1710 kBtuh)
V4730C1030	1-1/4			
V4734C1002	1-1/4	120 Vac, 50/60 Hz	2.6 A at start 1.04 A during operation	97-680 kW (326-2287 kBtuh) when used with VMU680 unit
V8730C1007	1/2	24 Vac, 50/60 Hz	1.56 A	22-150 kW (73-512 kBtuh)
V8730C1015	3/4			43-300 kW (146-1024 kBtuh)
V8730C1023	1		1.72 A	55-382 kW (185-1300 kBtuh) ^a /71 - 500 kW (245-1710 kBtuh)
V8730C1031	1-1/4			

^a When used with VMU335 Venturi UnitAnwendung

Maximum Operating Pressure (UL):

1.45 psi (100 mBar), except for 1-1/4 in. size:

(24V): 1 psi (70 mBar).

(120V): 1.45 psi (100mBar)

CSA Approved: 0.5 psi (34 mBar).

Note: CSA Certification to 1/2 psi.

Connections:

1/8 in. (3 mm) NPT pressure taps at inlet and outlet flanges. Eight flange connections are provided at the main body to mount either a pressure switch (high or low) or a ValveProving System (VPS).

Torsion and Bending Stress:

Pipe connections meet EN151, Group 2, requirements.

Electrical Equipment:

Standard DIN plug connector with 36-in. (914 mm) leadwires.

Valve Position Indicator Lamps:

Inboard (closest to the valve body) - V1.

Outboard - V2.

Ambient Temperature Range:

5°F to 140°F (-15°C to +60°C).

Coil Insulation Solenoid Valves:

Class H insulation system.

Body Material:

Aluminum alloy, die-cast

Strainer:

Fine mesh screen (0.135 in. [0.34 mm] diameter). AISI 303 steel, serviceable after removing inlet flange screws. Meets EN161 requirements for strainers

Seals and Gaskets:

Hydrocarbon-resistant NBR and Viton rubber types.

Flange Kit:

Consists of one flange with sealing plug, one O-ring and four screws. See Table 2.

Note: Valve comes with one kit only.

Table 2: Flange Kits.

Part Number	Size NPT in in. (mm)
32006652-001	1/2 (13)
32006652-002	3/4 (19)
32006652-003	1 (25)
32006652-004	1-1/4 (32)

Manual Shut-Off Valve Kits:

50002653-001 for use with 1 in. NPT or smaller valves.

50002653-002 for use with 1-1/4 in. NPT valves.

ORDERING INFORMATION

When purchasing replacement and modernization products from your TRADELINE® wholesaler or distributor, refer to the TRADELINE® Catalog or price sheets for complete ordering number. If you have additional questions, need further information, or would like to comment on our products or services, please write or phone:

1. Your local Honeywell Automation and Control Products Sales Office (check white pages of your phone directory).

2. Honeywell Customer Care

1885 Douglas Drive North

Minneapolis, Minnesota 55422-4386

In Canada - Honeywell Limited/Honeywell Limitée, 35 Dynamic Drive, Scarborough, Ontario M1V 4Z9.

International Sales and Service Offices in all principal cities of the world. Manufacturing in Australia, Canada, Finland, France, Germany, Japan, Mexico, Netherlands, Spain, Taiwan, United Kingdom, U.S.A.

Opening Time:

Dead time maximum: 1 second.

First valve opening: less than 1 second.

Second valve opening: reaches 50% of the adjustable outlet pressure within 5 seconds.

Maximum Allowable Leakage:

Outerwall: 3 cu. in./hr (50 cm³/h) at test pressure of 0.87 psi (6 mBar) and 7.83 psi (540 mBar).

First Valve: 2.5 cu. in./hr (40 cm³/h) at test pressure of 0.87 psi (6 mBar) and 7.83 psi (540 mBar).

Second Valve: 2.4 cu. in./hr (40 cm³/h) at test pressure of 0.87 psi (6 mBar) and 7.83 psi (540 mBar).

High Pressure Test:

In the OFF condition, the valve will withstand 21.75 psi (1.5 Bar) inlet pressure without damage.

Accessories:

FL020008 Mesh Screen.

Flange Kits (see Table 2).

DIN43650 Connector

32006653-001 Venturi O-rings/screws.

Operational Voltage Range:

The combination gas valve will function satisfactorily between 85% and 110% of the rated voltage.

Gas Valve Connection to Venturi (Field-Assembled):

Four screws and an O-ring are used to connect the gas valve to the venturi/manual shutoff valve.

The metal tube provided with the venturi must be connected between the venturi and the gas valve regulator.

Fan Connection:

The venturi is connected to the fan using six bolts (which are included with VMU).

Minimum Load:

The minimum load for which the system can be used is 14-17% of the reference load, which equals a minimum pressure differential of 0.2 in. wc (50 Pa) of the 1:1 venturi/servo regulator gas control.

Approvals:

Gas Appliance Directive 90.396/EEC

ANSI: Z21.21

CSA: 6.5

Capacity Curves:

See Fig. 9 to 14.

Dimensions:

See Fig. 1 to 5

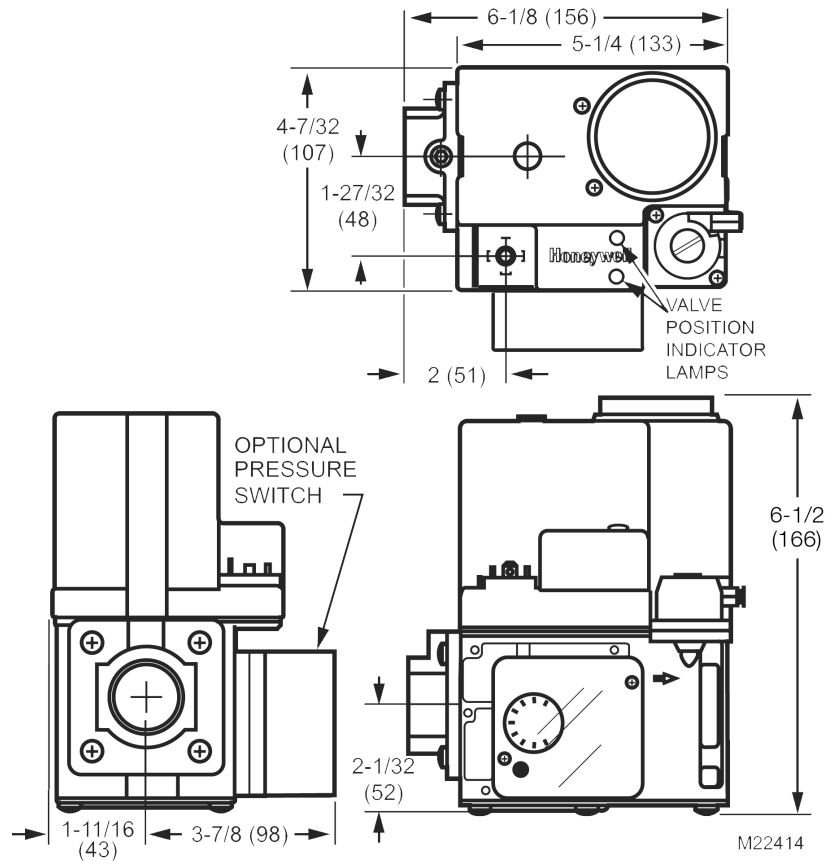

Fig. 1: V4730C/V8730C Gas Valves, 1/2 in. (13 mm) and 3/4 in. (19 mm) size, dimensions in in. (mm).

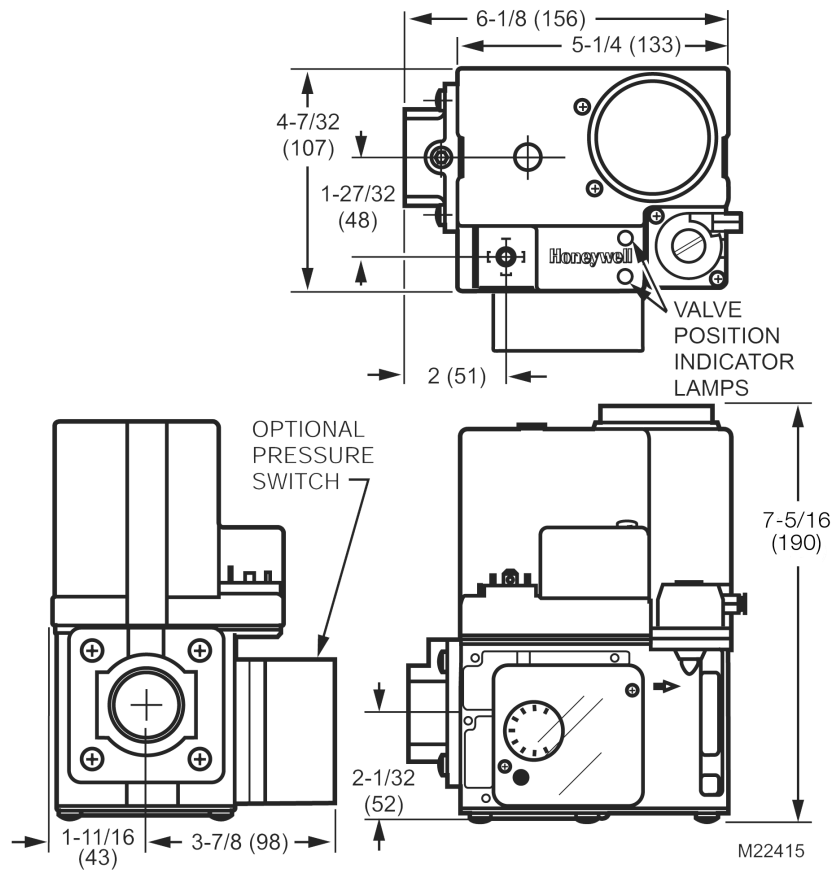

Fig. 2: V4730C/V8730C Gas Valves, 1 in. (25 mm) size, dimensions in in. (mm).

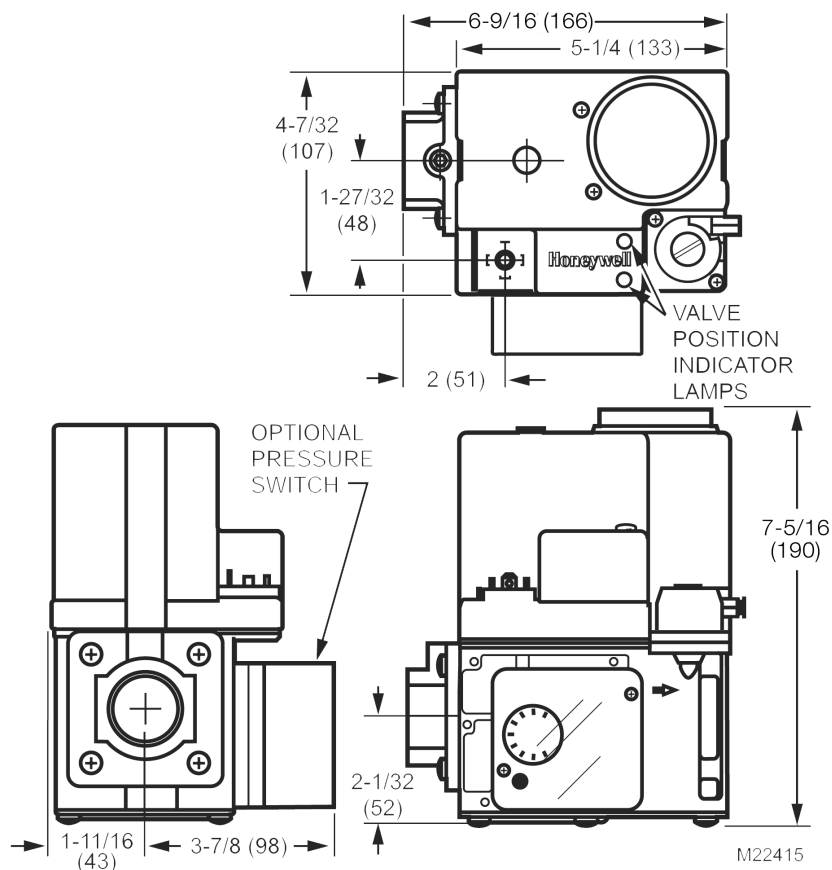

Fig. 3: V4730C/V8730C Gas Valves, 1-1/4 in. (32mm) size, dimensions in in. (mm).

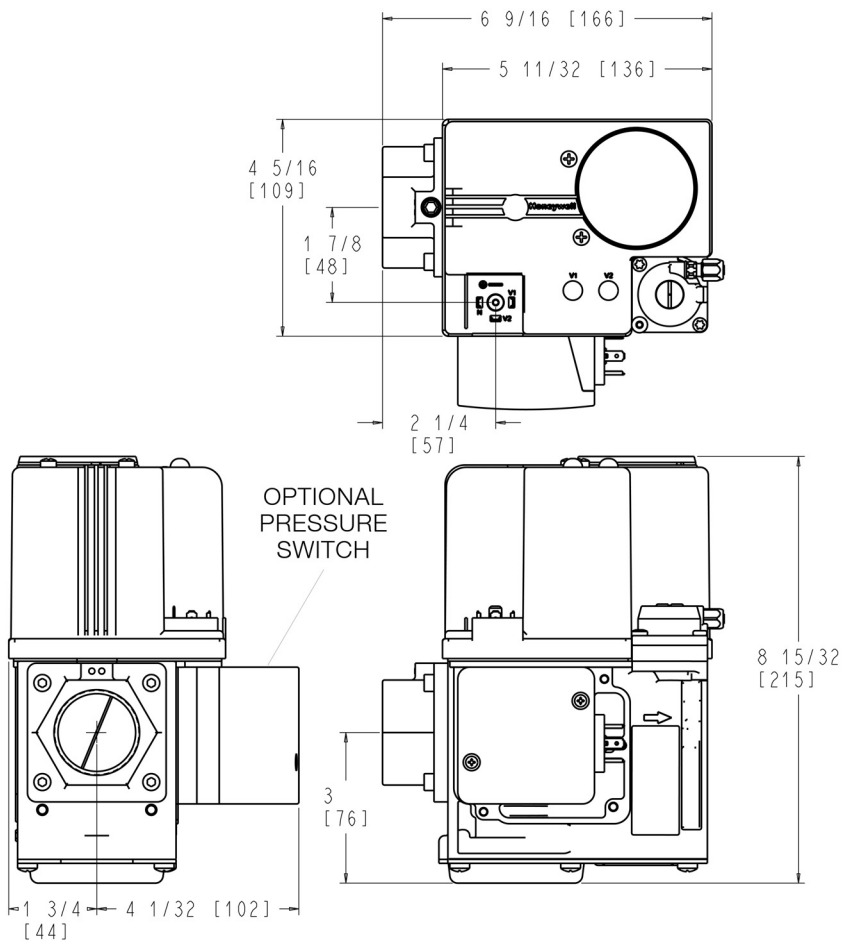

Fig. 4: V4734C Gas Valves 1-1/4 in. (32mm) size, dimensions in in. (mm).

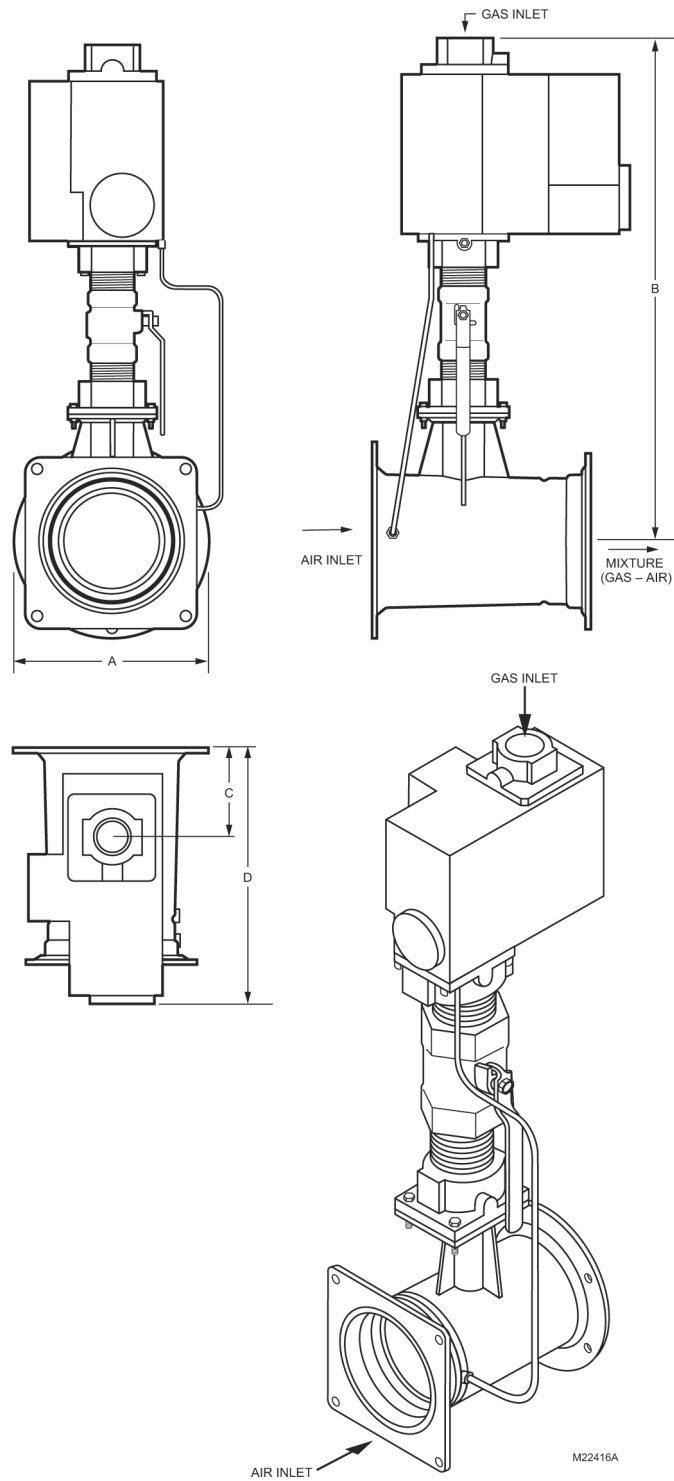

Fig. 5: Venturi 150-335 kW, with 1/2 in. to 1 in. gas valves and valve shutoff kit installed dimensions in in. (mm). See Table 3 for dimensions

Table 3: Dimensions in inches (millimeters)

Valve Size in inches	A	B	C	D
1/2, 3/4	6 - 1/4 (159)	15 - 15/16 (405)	2 - 15/16 (75)	7 - 7 1/2 (191)
1				8 - 5/16 (211)

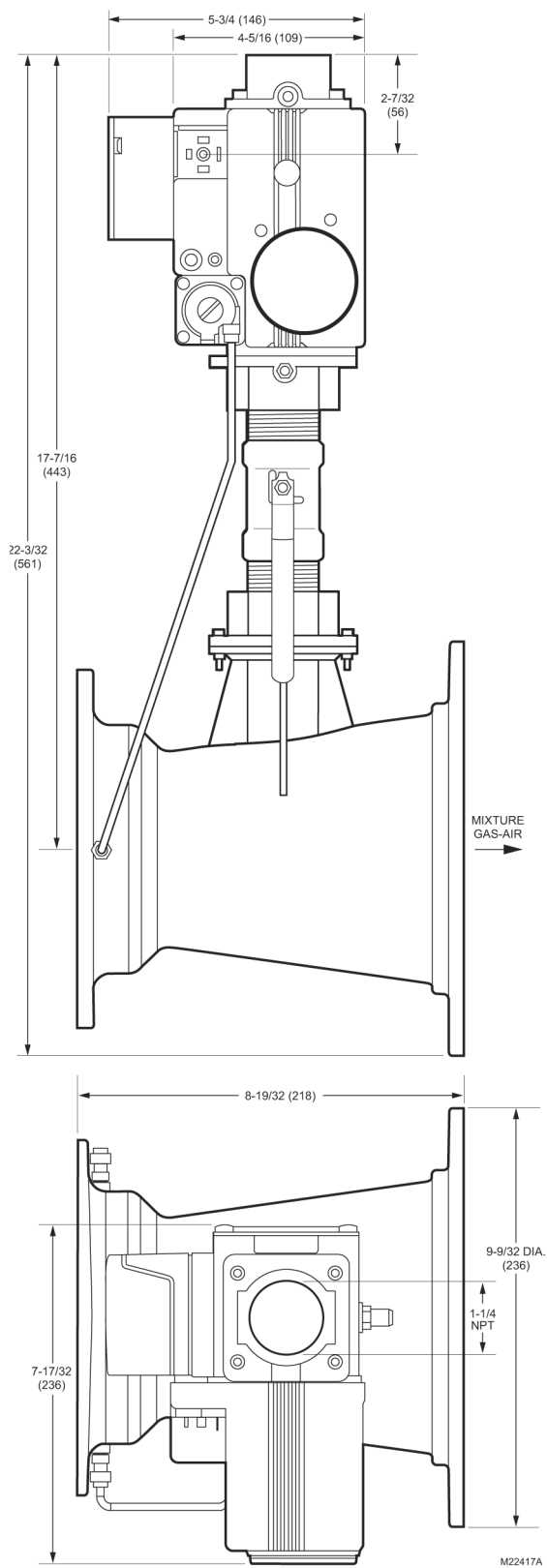

Fig. 6: Venturi 500kW, with V4730 gas valve and valve shutoff kit installed, dimensions in in. (mm), part 1.

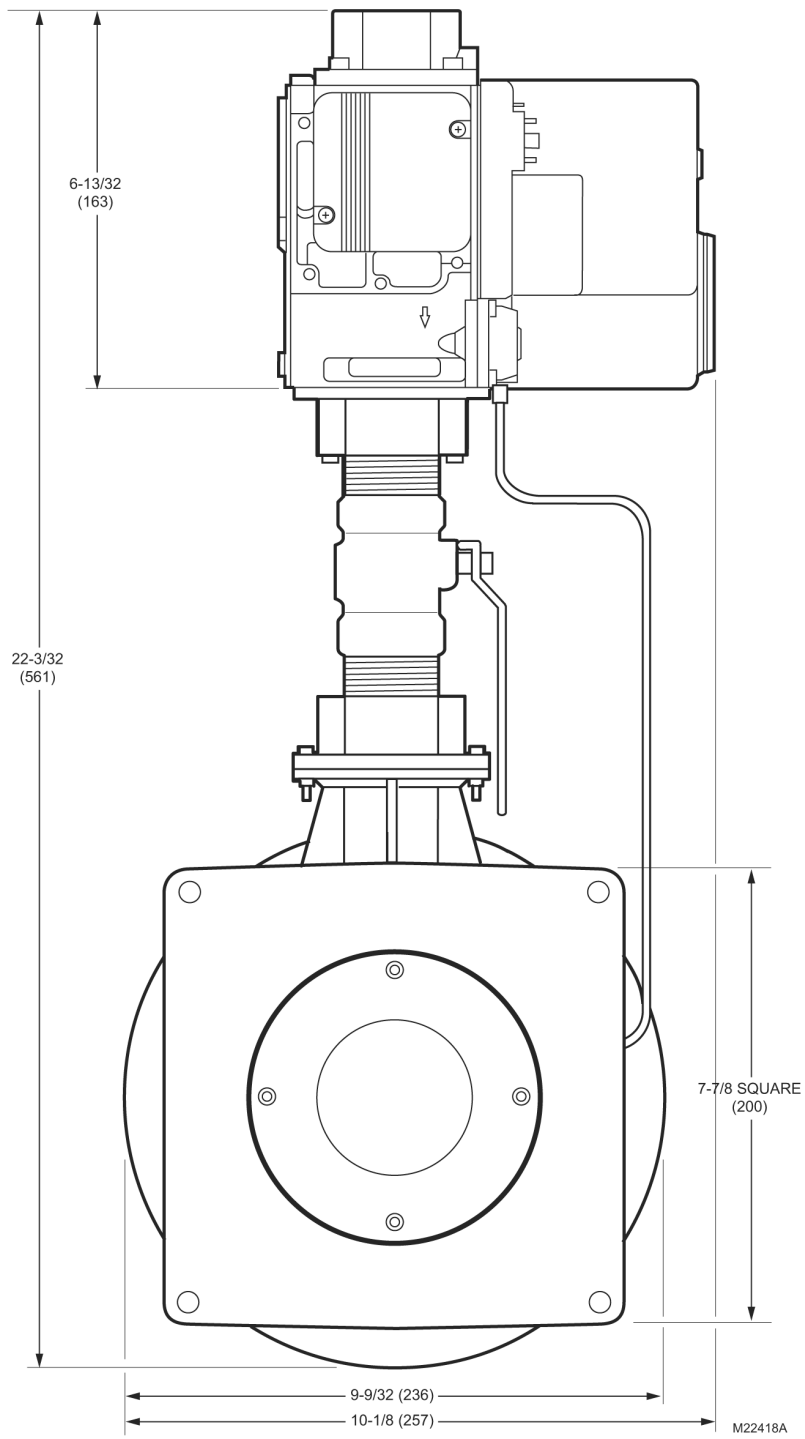

Fig. 7: Venturi, 500 kW, with V4730 gas valve and valve shutoff kit installed, dimensions in in. (mm), part 2

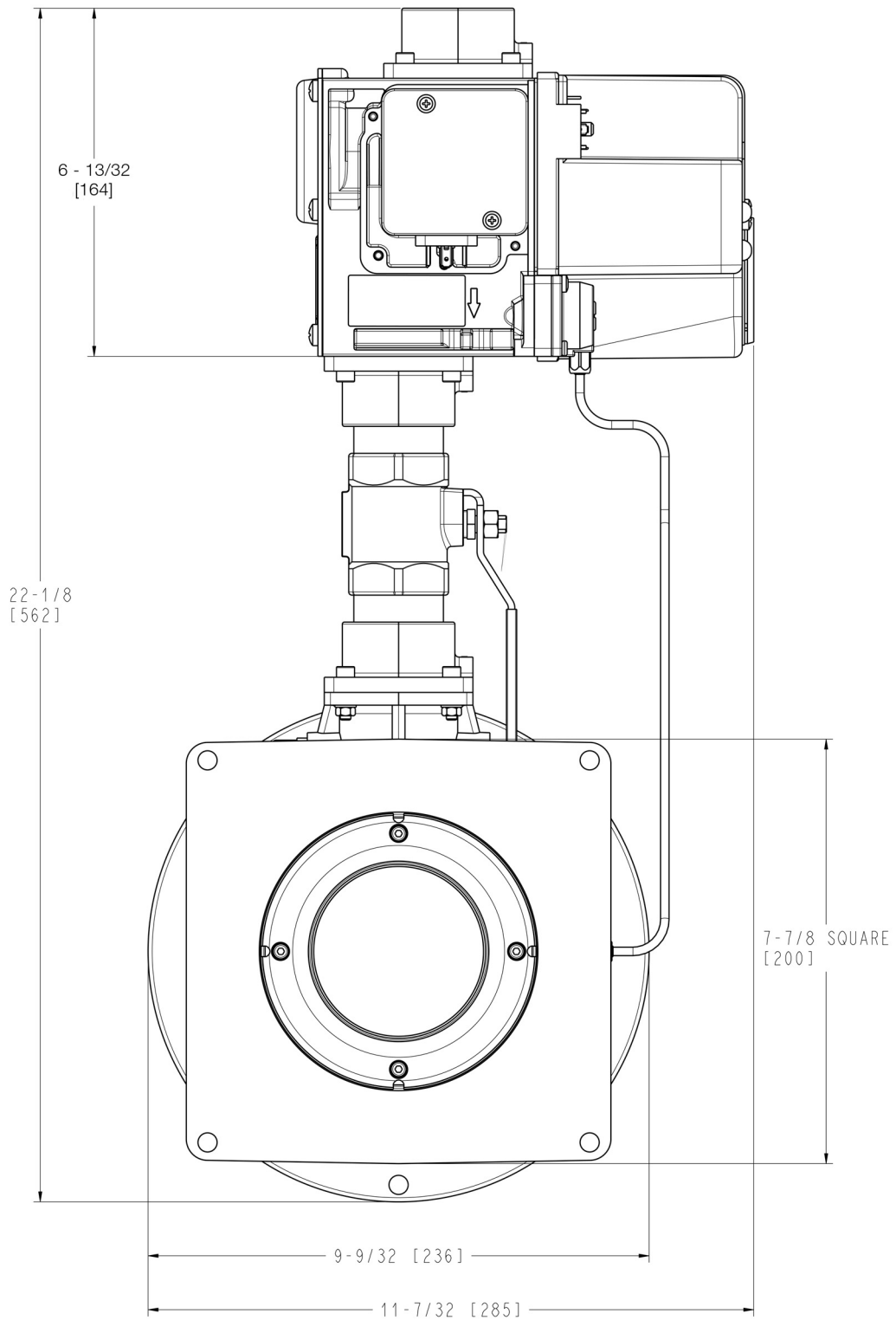

Fig. 8: V4734 + VMU 500/680

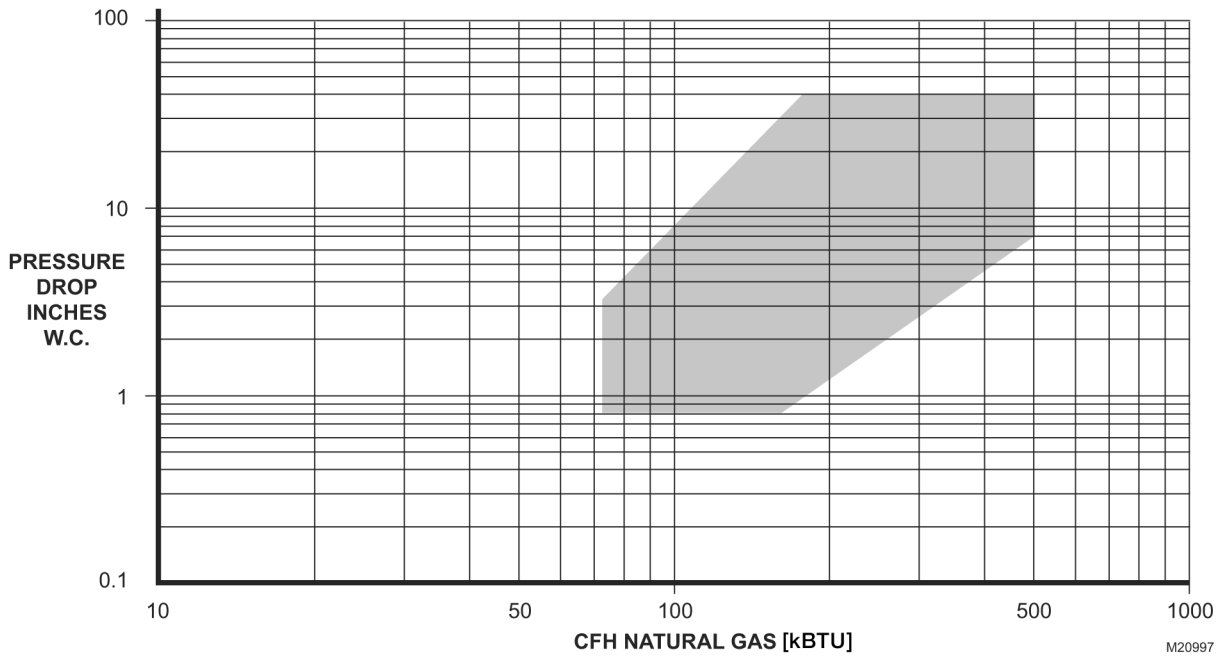

Fig. 9: Capacity curves for V4730C/V8730C and VMU 150 Venturi, 1/2 in. size.

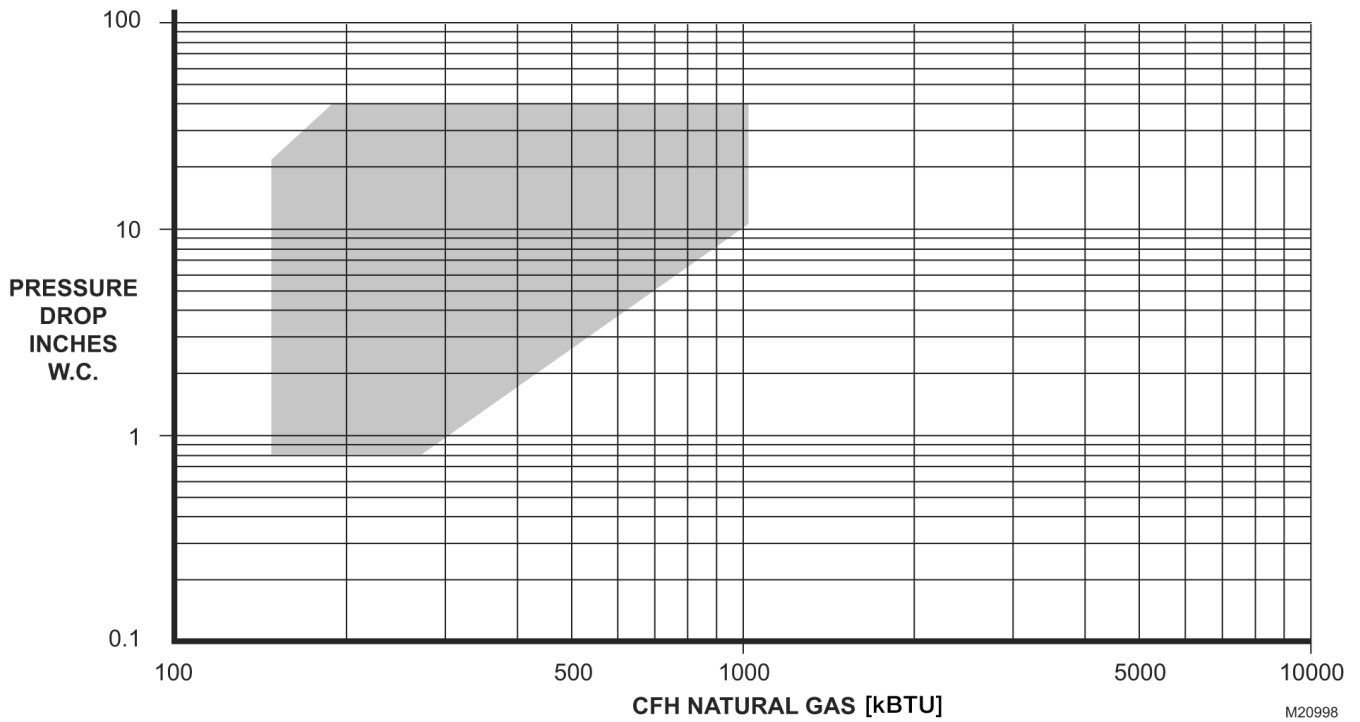

Fig. 10: Capacity curves for V4730C/V8730C and VMU 300 Venturi, 3/4 in. size

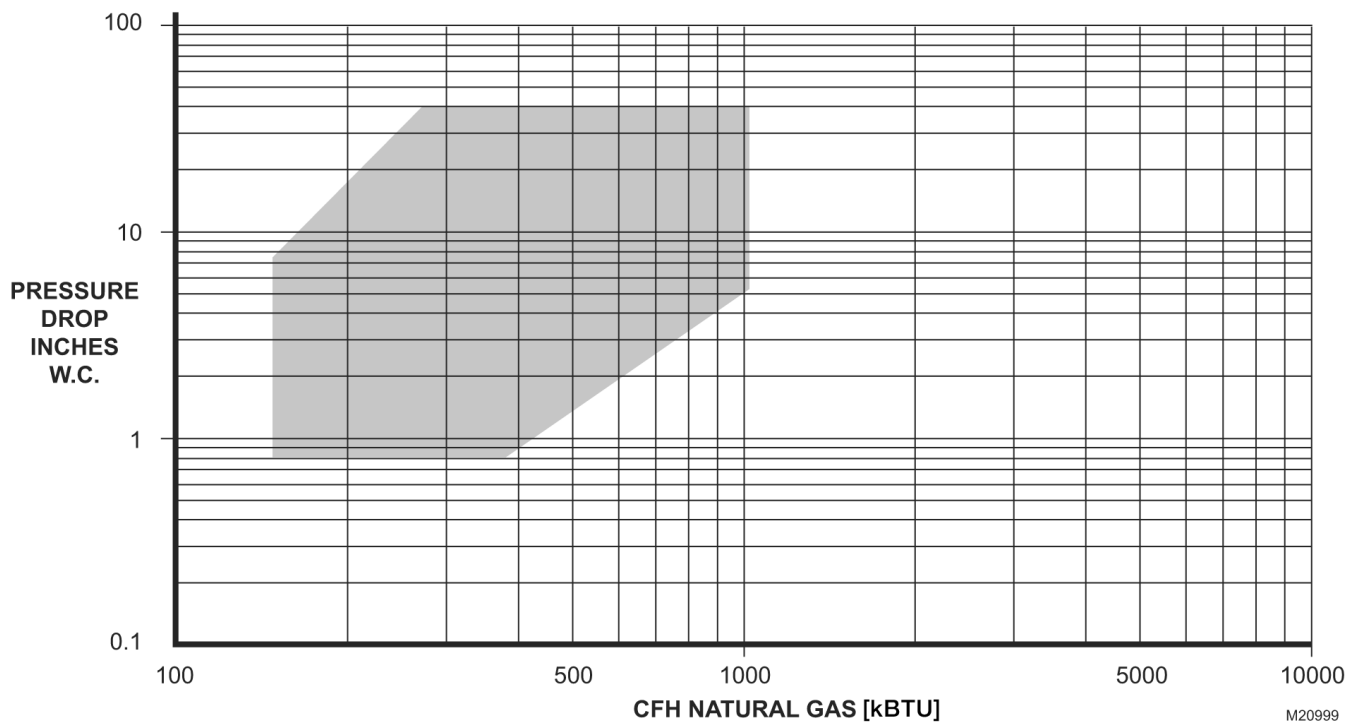

Fig. 11: Capacity curves for V4730C/V8730C and VMU 300 Venturi, 1 in. size.

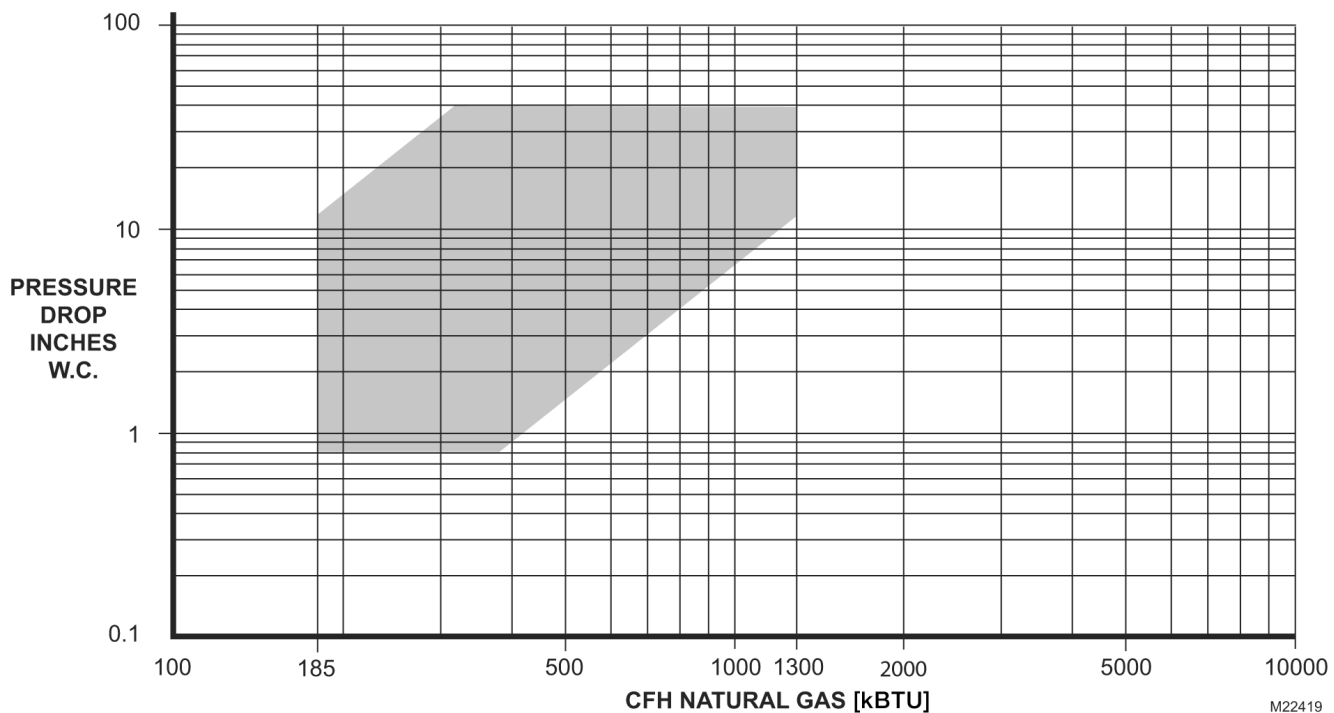

Fig. 12: Capacity curves for V4730C/V8730C and VMU 335 Venturi, 1-1/4 in. size.

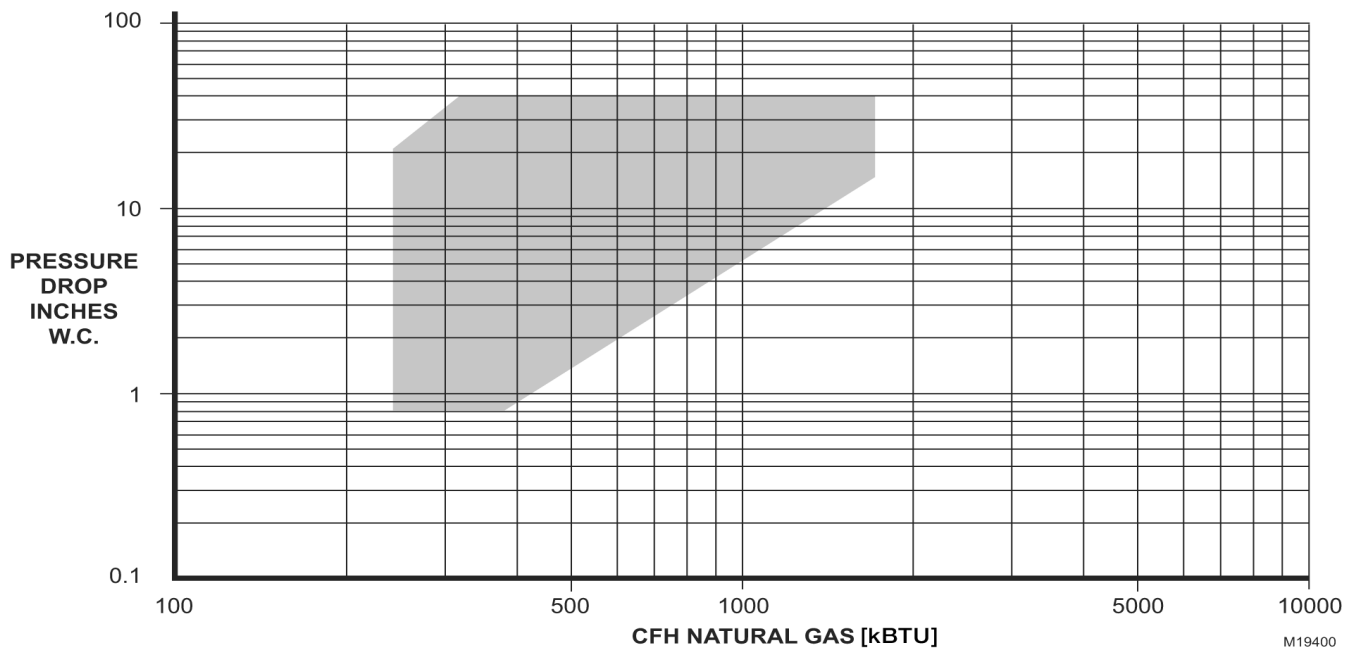

Fig. 13: Capacity curves for V4730C/V8730C and VMU 500 Venturi, 1-1/4 in. size.

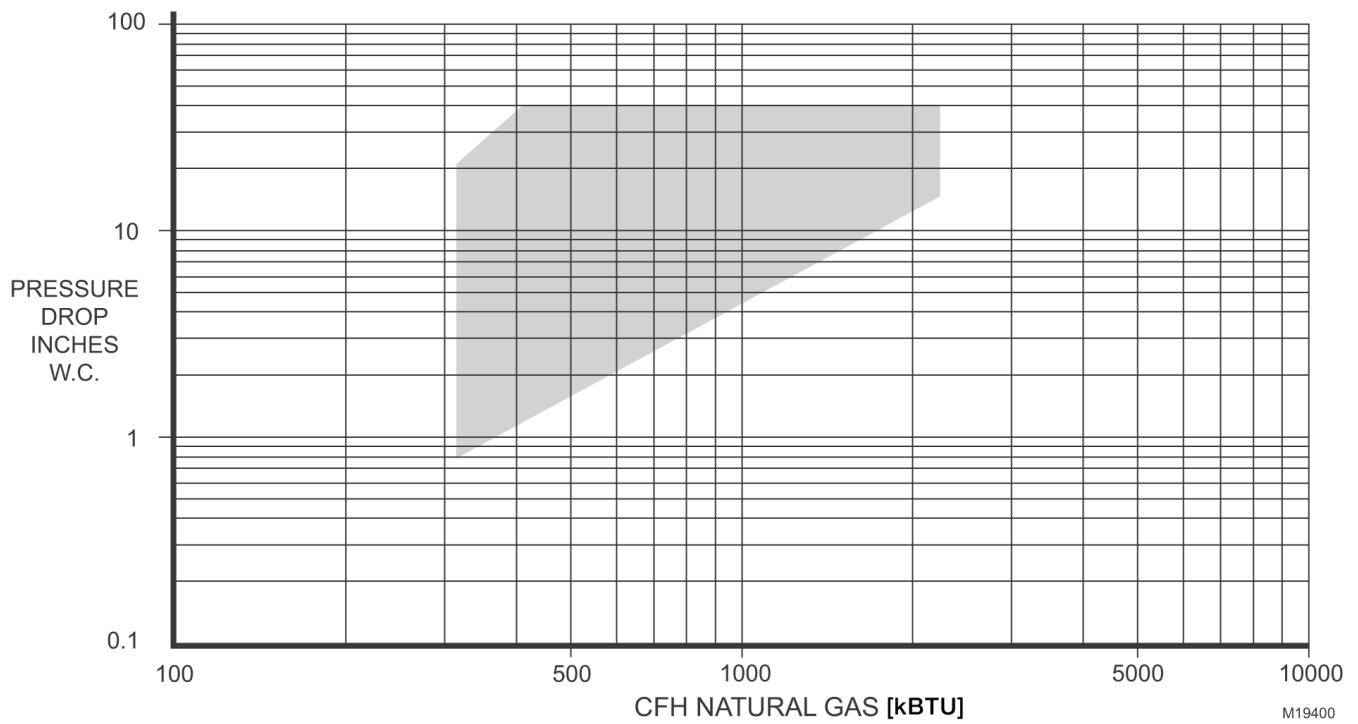

Fig. 14: Capacity curves for V4734C/V8734C and VMU 680 Venturi, 1-1/4 in. size.

INSTALLATION

When Installing This Product...

1. Read these instructions carefully. Failure to follow them could damage the product or cause a hazardous condition.
2. Check the ratings given in the instructions and on the product to make sure the product is suitable for your application.
3. The installer must be a trained, experienced, flame safeguard technician.
4. After installation is complete, check out product operation as provided in these instructions



WARNING

Fire or Explosion Hazard. Can cause severe injury, death or property damage

1. Turn off the gas supply before beginning installation
2. Disconnect power to the valve actuator before beginning installation to prevent electrical shock and damage to the equipment.
3. Do not remove the seal over the valve inlet and outlet until ready to connect piping.
4. The valve must be installed so that the arrow on the valve points in the direction of the gas flow, so that gas pressure helps to close the valve

Mounting Position

The valve/venturi is factory-calibrated in the upright position for the most accurate metering of the gas flow. This is with the air flow through the venturi in a horizontal direction and the gas flow into the valve in a horizontal direction. The valve can be mounted up to ± 90 degrees from this position without affecting the fuel/air metering at medium and high firing rates (3000 to 5000 rpm of the blower), but at lower firing rates (1000 rpm) the fuel might be reduced up to 10% when the valve is not mounted upright. To counter this, the low fire gas flow may be carefully field adjusted for non-upright mounting as follows:

1. With the valve in the final mounting position, adjust the venturi fan for the lowest burner firing rate.
2. Remove the slotted cap on the gas regulator using a slotted screwdriver. This will expose the offset adjustment screw (see Fig. 11).
3. Using a TORX® T40 or a 5 mm hex wrench, carefully adjust the low fire gas setting for proper combustion.
4. After proper low fire offset adjustment has been made, reinstall the slotted cap on the regulator.
5. Before commissioning the burner, check for proper lightoff and verify correct fuel/air mix and combustion quality throughout the entire firing range (from lowest to highest fan speeds used).

Mounting Locations

The distance between the gas valve and the wall/ground must be a minimum of 11-5/16 in. (30 cm).

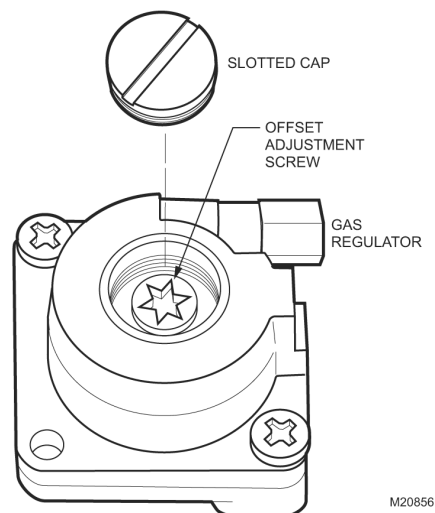

Fig. 15: Regulating adjusting screw

Main Gas Connection

1. Take care that dirt does not enter the gas valve during handling.
2. Remove the flanges from the valves.
3. Use new, properly reamed, pipe, free from chips.
4. Apply a moderate amount of good quality pipe dope, resistant to the action of liquefied petroleum (LP) gas, only on the pipe threads.
5. Screw the flanges onto the pipes.
6. Do not thread the pipe too far into the flange. Valve distortion or malfunction can result from excess pipe in the flange.
7. Make sure O-ring sealing surfaces are clean.
8. Using general purpose lithium grease, grease the O-ring.
9. Install the O-ring into the O-ring groove provided on the valve body (one O-ring per groove).
10. Mount the gas valve to the flanges, using the screws removed earlier.
11. Complete the electrical connections as instructed in the Electrical Connections section.



WARNING

Fire or Explosion Hazard. Can cause severe injury, death or property damage.

Perform a soap-and-water solution gas leak test any time work is done on a gas system.

ELECTRICAL CONNECTIONS



WARNING

Electrical Shock Hazard. Can cause severe injury or death.

Disconnect the power supply before beginning wiring to prevent electrical shock. More than one disconnect may be involved.

Wiring

1. Use 14, 16 or 18 AWG copper conductor, 600 volt insulation, moisture-resistant wire for line voltage connections. Recommended wire types are TTW60C, THW75C or THHN90C.
2. Follow the instructions below for wiring the gas valve. See Fig. 16 and 17 for reference.
 - 2.a T1 (yellow) will be L2 (120 Vac or 24 Vac).
 - 2.b T2 (black) will be L1 (120 Vac or 24 Vac) to Valve 1.
 - 2.c T3 (blue) will be L1 (120 Vac or 24 Vac) to Valve 2.
 - 2.d Ground (green) will be earth ground.

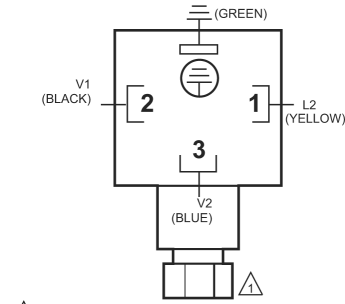

FOR CONNECTION TO 1/2 INCH FLEXIBLE ELECTRICAL CONDUIT ONLY. MAXIMUM TORQUE 65 INCH-POUNDS. M20583

Fig. 16: Four-pin electrical plug connector

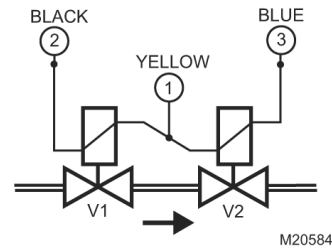

Fig. 17: Electrical connection diagram

ADJUSTMENTS AND FINAL CHECKOUT

The following procedures are related to the adjustments on the main gas valve. For adjustments of the other devices (i.e., pressure switches), refer to the instructions supplied with the applicable device.



WARNING

Fire or Explosion Hazard. Can cause severe injury, death or property damage.

Only fully qualified, experienced, flame safeguard technicians should make adjustments on the valve.

Pressure Tap Points (Fig. 18)

The V4730C/V8730C/V4734C Valves have a number of connection points (1/8 in. [3 mm] NPT plugs) for measuring pressure and/or mounting a pressure switch. The pressure tap points are:

- 1 inlet pressure at first SSOV flange tap.
 - 2 inlet pressure at first SSOV.
 - P outlet pressure at first SSOV.
 - 3 inlet pressure at second SSOV.
 - 4 outlet pressure at second SSOV flange tap.
- The following pressures can be measured:
1. Inlet pressure-tap on inlet flange (1).
 2. Pressure after inlet screen (2).
 3. Unregulated intermediate pressure-pressure between the two shutoff seats (P).
 4. Regulated intermediate pressure-pressure between the shutoff valves (3).
 5. Outlet pressure-tap from flange (4).

The corresponding numbers (2, P, 3) can be found on the side of the valve.

Note: To mount the C6097 Pressure Switch, refer to instructions in form number 65-0237, furnished with the switch. The pressure switch can be mounted to 2, P, or 3 on either side of the valve.

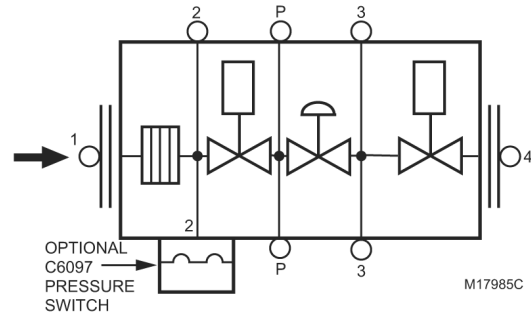

Fig. 18: Pressure tap points

Second Valve, Fast Opening

Flow rate is adjusted from 0% to 100% of full rated flow. To adjust the flow rate:

1. Remove the flat, round, blue plastic cap from the cover. Using a 3 mm (7/64 in.) hex wrench, turn the adjustment screw counterclockwise to increase or clockwise to decrease the flow rate.
2. Snap the flat, round, blue plastic cap back onto the cover.

Final Checkout of the Installation

Set the system in operation after any adjustment is completed and observe several complete cycles to ensure that all burner components function correctly.

OPERATION

The V4730C/V8730C/V4734C are normally closed valves. The valves open when energized and close when power is removed.



WARNING

Explosion and Electrical Shock Hazard. Can cause severe injury, death or property damage.

1. Do not put the system into service until you have satisfactorily completed the Valve Leak Test, all applicable tests described in the Checkout section of the instructions for the flame safeguard control, and any other tests required by the burner manufacturer.
2. All tests must be performed by a trained, experienced, flame safeguard technician.
3. Close all manual fuel shutoff valves immediately if trouble occurs.

After the installation is complete, cycle the valve several times with the manual fuel shutoff valve cock closed. Make sure the valve functions properly. Also, perform the Valve Leak Test before putting the valve into service.

Valve Leak Test (Fig. 19)

This is a test for checking the closure tightness of the gas shutoff valve. It should be performed only by trained, experienced, flame safeguard technicians during the initial startup of the burner system or whenever the valve is replaced. It is recommended that this test should also be included in the scheduled inspection and maintenance procedures. For a periodic inspection test, follow steps 1, 3, 4, 5, 8, 9, 10, 12, 13, 17, and 18.



WARNING

Electrical Shock Hazard. Can cause severe injury or death.

Remove the power from the system before beginning the valve leak test to prevent electrical shock. More than one disconnect may be involved.

1. De-energize the control system to make sure no power goes to the valves.
2. Close the upstream manual gas cock (A).
3. Make sure the manual test petcock (F) is closed in the leak test tap assembly.
4. To test the first SSOV, remove the 1/8 in. (3mm) NPT plug from pressure tap point P.
5. Install the leak test tap into pressure tap point P on the valve body.
6. Open the upstream manual gas cock (A) to repressurize the first SSOV.
7. Immerse the 1/4 in. (6 mm) tube vertically 1/2 in. (13 mm) in a jar of water.
8. Slowly open the manual test petcock (F).
9. When the rate of bubbles coming through the water stabilizes, count the number of bubbles appearing during a ten-second period. Each bubble appearing represents a flow rate of 0.001 cfh (28 cch). See Table 4.
10. Close the upstream manual gas cock (A).
11. Remove the leak test tap from the valve body.
12. Using a small amount of pipe sealant on the 1/8 in. (3 mm) NPT plug, reinstall the plug in pressure tap point P

13. To test the second SSOV, remove the 1/8 in. (3 mm) NPT plug from the flange pressure tap point 4.
14. Install the leak test tap into pressure tap point 4.
15. Close the downstream manual gas cock (E).
16. Energize the first SSOV

Table 4: max. bubbles per pipe size

Pipe Size (in. NPT)	Maximum Seat Leakage (UL)	Maximum Number of Bubbles in 10 seconds
1/2 - 3/4	235 cch	6
1	275 cch	7
1 - 1/4	340 cch	8

17. Immerse the 1/4 in. (6 mm) tube vertically 1/2 in. (13mm) into a jar of water.
18. Slowly open the manual test petcock (F).
19. When the rate of bubbles coming through the water stabilizes, count the number of bubbles appearing during a ten-second period. Each bubble appearing during a 10-second period represents a flow rate of 0.001 cfh (28 cch). See Table 4.
20. De-energize First SSOV
21. Remove the leak test tap from the valve body.
22. Using a small amount of pipe sealant on the 1/8 in. (3 mm) NPT plug, reinstall the plug in pressure tap point 4.

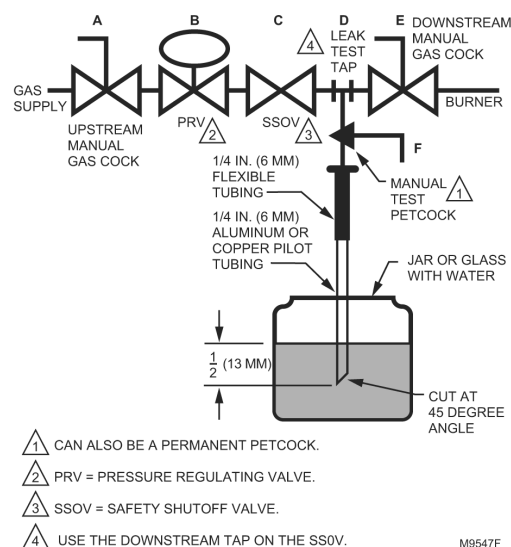

Fig. 19: Valve leak test

After the Test

1. . Make sure the downstream manual gas cock (E) is closed.
2. Open the upstream manual gas cock (A) and energize the valve through the safety system.
3. Test with rich soap and water solution to make sure there is no leak at the test tap (D) or any pipe adapter/valve mating surfaces.
4. De-energize the valve (C).
5. Open the downstream manual gas cock (E).
6. Restore the system to normal operation.

TROUBLESHOOTING



WARNING

Electrical Shock Hazard. Can cause severe injury, death or property damage.

Use extreme caution when troubleshooting; line voltage is present.



IMPORTANT

Do not replace the valve until all other sources of trouble are eliminated.

Troubleshooting Procedure

If the valve does not open when the thermostat or controller calls for heat:

1. Check for voltage at the valve leadwires or terminal block.
2. If there is no voltage at the valve leadwires or terminal block, make sure:
 - 2.a voltage is connected to the master switch.
 - 2.b master switch is closed and overload protection (circuit breaker, fuse, or similar device) has not opened the power line.

3. If there is still no voltage at the valve leadwires or terminal block, make sure all appropriate contacts in the thermostat or controller, limits and flame safeguard control are closed. If one or more are open, determine the cause(s); correct the trouble and proceed.
4. If there is proper voltage at the valve but the valve still does not open, check for normal gas pressure.
5. If the valve still does not open, replace the valve.

If the valve does not close when one or more of the appropriate contacts in the thermostat, controller, limits or flame safeguard control is open:

1. Make sure the valve is wired in the correct circuit.
2. Open the master switch to remove power from the valve.
3. If the valve closes now, check the wiring for the valve and correct the wiring as necessary.
4. Check for a short in the electrical circuit and repair it as necessary.

SERVICE INFORMATION



WARNING

Explosion Hazard and Electrical Shock Hazard. Can cause severe injury, death or property damage.

Turn off gas supply and disconnect all electrical power to the valve before servicing.



IMPORTANT

Only trained, experienced, flame safeguard technicians should attempt to service or repair flame safeguard controls and burner assemblies.

5. Clean the strainer by using compressed air, or replace the strainer.
6. Install the cleaned strainer or new strainer.
7. Make sure O-ring sealing surface is clean on the flange.
8. Using general purpose lithium grease, grease the O-ring.
9. Apply a moderate amount of good quality pipe dope, resistant to the action of LP gas, only on the pipe threads.
10. Install the O-ring in the O-ring groove provided on the flange/valve body (one O-ring per groove).
11. Screw the flange onto the pipe.
12. Mount the gas valve to the flange, using the bolts and nuts for each flange.
13. Apply power to the valve.
14. Turn on the main gas supply.
15. Complete the valve leak test.
16. Return the valve to service.

Scheduled Inspection and Maintenance

Set up and follow a schedule for periodic inspection and maintenance, including the burner, all other controls and the valves. It is recommended that the valve leak test in the Checkout section be included in this schedule. Refer to the instructions for the primary safety control (s) 0 for more inspection and maintenance information.

Screen/Strainer Replacement

1. Make sure the gas supply is turned off and all electrical power has been removed.
2. Remove bolts/nuts from flange/valve.
3. Remove flange from gas supply pipe.
4. Remove old screen/strainer.

Automation & Control Solutions Combustion Controls Europe

Honeywell BV
Phileas Foggstraat 7
7821 AJ Emmen
The Netherlands
Tel.: +31 (-) 591 695911
Fax.: +31 (-) 591 695200
<http://europe.hbc.honeywell.com>

Manufactured for and on behalf of the
Environment and Combustion Controls
Division of Honeywell Technologies Sàrl,
Ecublens, Route du Bois 37, Switzerland
by its Authorised Representative.

EN0H-0281NL05-R1006
Subject to change without notice
© 2006 Automation & Control Solutions
Combustion Controls Europe

Honeywell