

## VA Series

### VAG... Valve Actuator Assemblies with VKG Butterfly Valves and Gxx... Actuators

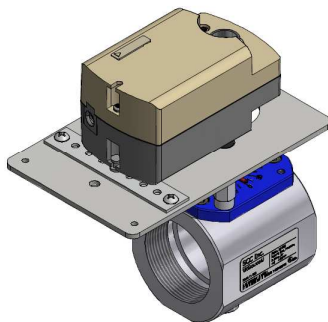

VAGQD...

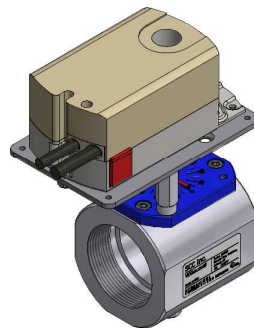

VAGDE...

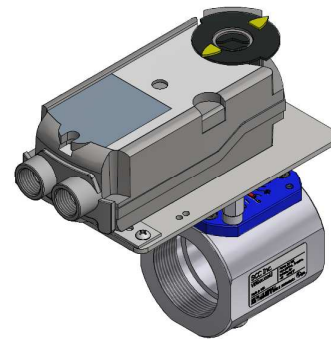

VAGAP.../VAGMA.../VAGNP...

#### Description

VAG... valve actuator assemblies include a Siemens Gxx... actuator reliably mounted to a VKG... butterfly valve to control the flow of natural gas, propane, butane, or air.

#### Features

- Exclusive, patented technology\*
- Fail-safe spring return options available
- Models with dual, independent auxiliary switches available
- VKG... valve sizes available from ½" to 4"
- Includes Siemens GAP..., GDE..., GMA..., GNP..., or GQD... rotary actuator
- Modular design enables field actuator clocking in 90° increments

#### Application

VAG... valve actuator assemblies mount a GAP..., GDE..., GMA..., GNP..., or GQD... actuator to a VKG... butterfly valve. The VKG... valve and Gxx... actuator are rigidly mounted with Siemens engineered brackets and couplings to ensure precise shaft alignment. VKG technical instructions (CVLV-2000) provide sizing and additional valve information.

\*Patented under US Patent No. 9,915,352

## Product Part Numbers

The following chart provides VAG... assembly part number identification including a GAP..., GDE..., GMA..., GNP..., or GQD... actuator. Technical instructions for GAP.../GNP... (155-771), GDE... (155-187P25), GMA... (155-315P25), or GQD... (155-760) actuators are available at [www.scccombustion.com](http://www.scccombustion.com).

### VA GQD151.1P - N F - 200

#### Valve Actuator Assembly

##### Actuator Model

GAP191.1P (24 VAC/DC, 53 in-lb, multiple input choices, 0-10 VDC feedback, plenum cable)  
 GAP196.1P (24 VAC/DC, 53 in-lb, multiple input choices, 0-10 VDC feedback, dual aux., plenum cable)  
 GDE161.1N (24 VAC, 44 in-lb, 0-10 VDC input, post header AMP connection)  
 GDE161.1P (24 VAC, 44 in-lb, 0-10 VDC input, 0-10 VDC feedback, plenum cable)  
 GDE161.1Q (24 VAC, 44 in-lb, 0-10 VDC input, 0-10 VDC feedback, 6 foot standard cable)  
 GDE161.1T (24 VAC, 44 in-lb, 0-10 VDC input, terminal strip connection)  
 GDE163.1P (24 VAC, 44 in-lb, 0-10 VDC input, 0-10 VDC feedback, plenum cable, adj. slope / offset)  
 GDE164.1P (24 VAC, 44 in-lb, 0-10 VDC input, 0-10 VDC feedback, dual aux., plenum cable, adj. slope / offset)  
 GDE166.1P (24 VAC, 44 in-lb, 0-10 VDC input, 0-10 VDC feedback, dual aux., plenum cable)  
 GMA121.1U (24 VAC/DC, 62 in-lb, spring return, 2-position input, standard cable)  
 GMA131.1U (24 VAC/DC, 62 in-lb, spring return, 3-position input, standard cable)  
 GMA166.1U (24 VAC/DC, 62 in-lb, spring return, 0-10 VDC input, 0-10 VDC feedback, dual aux., standard cable)  
 GMA221.1U (120 VAC, 62 in-lb, spring return, 2-position input, standard cable)  
 GMA226.1U (120 VAC, 62 in-lb, spring return, 2-position input, dual aux., standard cable)  
 GNP191.1P (24 VAC/DC, 53 in-lb, spring return, multiple input choices, 0-10 VDC feedback, plenum cable)  
 GQD121.1P (24 VAC/DC, 20 in-lb, spring return, 2-position input, plenum cable)  
 GQD151.1P (24 VAC/DC, 20 in-lb, spring return, 2-10 VDC input, 2-10 VDC feedback, plenum cable)  
 GQD156.1P (24 VAC/DC, 20 in-lb, spring return, 2-10 VDC input, 2-10 VDC feedback, dual aux., plenum cable)  
 GQD221.1U (120 VAC, 20 in-lb, spring return, 2-position input, appliance cable)  
 GQD226.1U (120 VAC, 20 in-lb, spring return, 2-position input, dual aux., appliance cable)

##### Pipe Thread

N = NPT

##### Port Size

F = Full Port  
 M = Medium Port  
 R = Reduced Port

##### Pipe Size

(mm)	(inches)	
050H	= 1/2"	→ Full port only
075	= 3/4"	→ Full port only
100	= 1"	→ Full port & medium port
125	= 1-1/4"	→ Full port & medium port
150	= 1-1/2"	
200	= 2"	
250	= 2-1/2"	
300	= 3"	
400	= 4"	

## Product Part Numbers (continued)

The following chart provides a summary of the features of each Gxx... actuator that can be used with a VAG... valve actuator assembly.

**Table 1: Critical Features of Each Gxx... Actuator**

Actuator Model	Operating Voltage	Torque (in-lb)	Spring Return	Dual Aux. Switches	Electrical Connection	Slope / Offset Adjustable	Control Signal	Position Feedback Signal
GAP191.1P	24 VAC/DC	53	No	No	Plenum cable	No	2-position, 3-position, 0/2-10 VDC, or 0/4-20 mA	0-10 VDC
GAP196.1P	24 VAC/DC	53	No	Yes	Plenum cable	No	2-position, 3-position, 0/2-10 VDC, or 0/4-20 mA	0-10 VDC
GDE161.1N	24 VAC	44	No	No	Post header AMP	No	0-10 VDC	No
GDE161.1P	24 VAC	44	No	No	Plenum cable	No	0-10 VDC	0-10 VDC
GDE161.1Q	24 VAC	44	No	No	6 foot length	No	0-10 VDC	0-10 VDC
GDE161.1T	24 VAC	44	No	No	Terminal strip	No	0-10 VDC	No
GDE163.1P	24 VAC	44	No	No	Plenum cable	Yes	0-10 VDC	0-10 VDC
GDE164.1P	24 VAC	44	No	Yes	Plenum cable	Yes	0-10 VDC	0-10 VDC
GDE166.1P	24 VAC	44	No	Yes	Plenum cable	No	0-10 VDC	0-10 VDC
GMA121.1U	24 VAC/DC	62	Yes	No	Standard cable	No	2-position	No
GMA131.1U	24 VAC/DC	62	Yes	No	Standard cable	No	3-position	No
GMA166.1U	24 VAC/DC	62	Yes	Yes	Standard cable	No	0-10 VDC	0-10 VDC
GMA221.1U	120 VAC	62	Yes	No	Standard cable	No	2-position	No
GMA226.1U	120 VAC	62	Yes	Yes	Standard cable	No	2-position	No
GNP191.1P	24 VAC/DC	53	Yes	No	Plenum cable	No	2-position, 3-position, 0/2-10 VDC, or 0/4-20 mA	0-10 VDC
GQD121.1P	24 VAC/DC	20	Yes	No	Plenum cable	No	2-position	No
GQD151.1P	24 VAC/DC	20	Yes	No	Plenum cable	No	2-10 VDC / 10-2 VDC	2-10 VDC / 10-2 VDC
GQD156.1P	24 VAC/DC	20	Yes	Yes	Plenum cable	No	2-10 VDC / 10-2 VDC	2-10 VDC / 10-2 VDC
GQD221.1U	120 VAC	20	Yes	No	Appliance cable	No	2-position	No
GQD226.1U	120 VAC	20	Yes	Yes	Appliance cable	No	2-position	No

---

## Installation

- Gxx... actuators are clockable relative to the VKG... valve. To change the orientation of the actuator, perform the following steps:
  1. Loosen actuator clamp
  2. Remove (2) pan head screws holding down anti-rotation bracket
  3. Lift actuator off assembly
  4. Remove (2) M6 flat socket head cap screws and remove bracket
  5. If necessary, unthread (2) hex standoffs and move to other set of mounting holes
  6. Re-install (2) M6 flat socket head cap screws and bracket
  7. Slide actuator over shaft adapter and onto anti-rotation pin
  8. Re-install (2) pan head screws to hold down anti-rotation bracket
  9. Tighten actuator clamp
- Red pointer on VKG... valve shows valve position after installation.
- VKG... valves can accommodate flow in either direction.

## Dimensions

Dimensions in inches [mm]

### VAGAP.../VAGMA.../VAGNP... Valve Actuator Assemblies

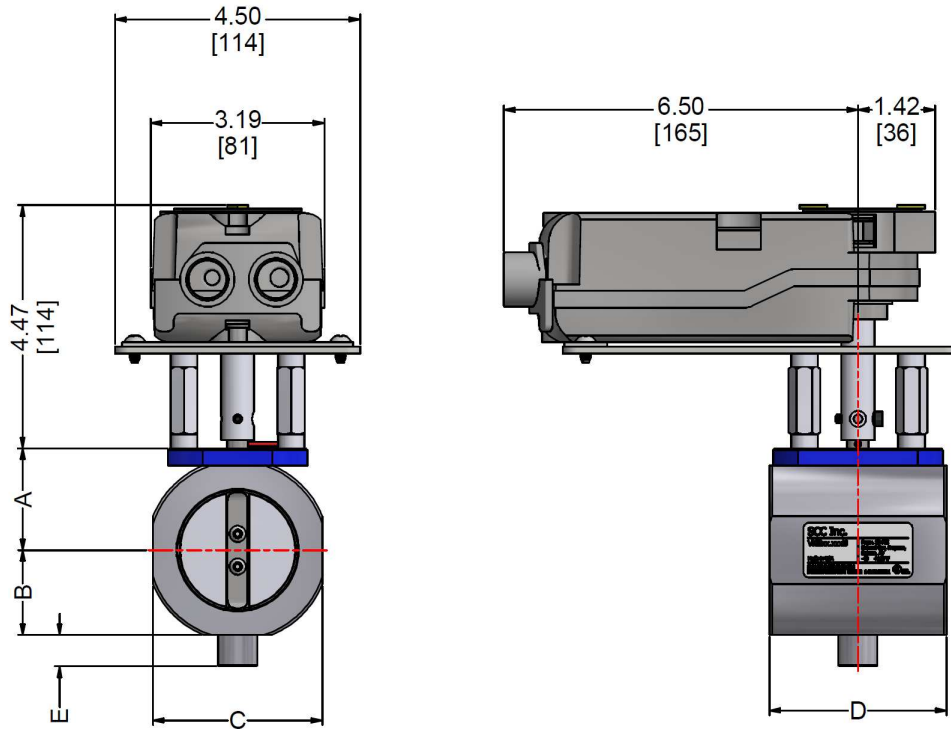

**Table 2: VAGAP.../VAGMA.../VAGNP... Dimensions**

Assembly Part Number Suffix	A	B	C	D	E
050H	1.35 [34]	1.12 [29]	2.08 [53]	3.25 [83]	0.21 [5]
075	1.35 [34]	1.04 [26]	2.08 [53]	3.25 [83]	0.58 [15]
100	1.35 [34]	1.04 [26]	2.08 [53]	3.25 [83]	0.58 [15]
125	1.53 [39]	1.22 [31]	2.44 [62]	3.25 [83]	0.58 [15]
150	1.63 [41]	1.31 [33]	2.63 [67]	3.25 [83]	0.58 [15]
200	1.87 [47]	1.55 [39]	3.11 [79]	3.25 [83]	0.58 [15]
250	2.18 [55]	1.87 [47]	3.74 [95]	4.38 [111]	0.58 [15]
300	2.44 [62]	2.13 [54]	4.26 [108]	4.38 [111]	0.58 [15]
400	2.96 [75]	2.64 [67]	5.28 [134]	5.00 [127]	0.58 [15]

## Dimensions (continued)

Dimensions in inches [mm]

### VAGDE... Valve Actuator Assemblies

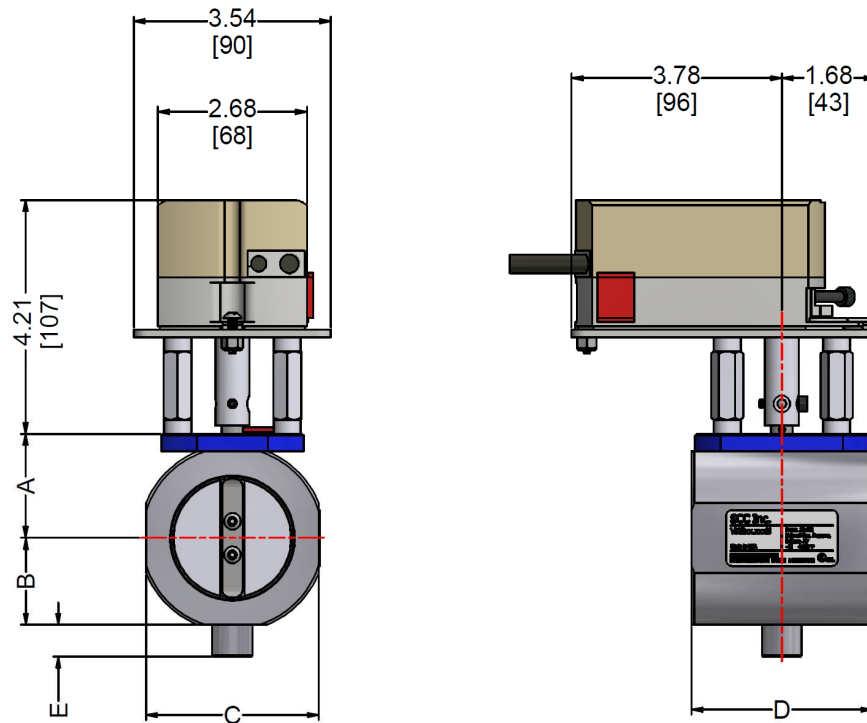

**Table 3: VAGDE... Dimensions**

Assembly Part Number Suffix	A	B	C	D	E
050H	1.35 [34]	1.12 [29]	2.08 [53]	3.25 [83]	0.21 [5]
075	1.35 [34]	1.04 [26]	2.08 [53]	3.25 [83]	0.58 [15]
100	1.35 [34]	1.04 [26]	2.08 [53]	3.25 [83]	0.58 [15]
125	1.53 [39]	1.22 [31]	2.44 [62]	3.25 [83]	0.58 [15]
150	1.63 [41]	1.31 [33]	2.63 [67]	3.25 [83]	0.58 [15]
200	1.87 [47]	1.55 [39]	3.11 [79]	3.25 [83]	0.58 [15]
250	2.18 [55]	1.87 [47]	3.74 [95]	4.38 [111]	0.58 [15]
300	2.44 [62]	2.13 [54]	4.26 [108]	4.38 [111]	0.58 [15]
400	2.96 [75]	2.64 [67]	5.28 [134]	5.00 [127]	0.58 [15]

## Dimensions (continued)

Dimensions in inches [mm]

### VAGQD... Valve Actuator Assemblies

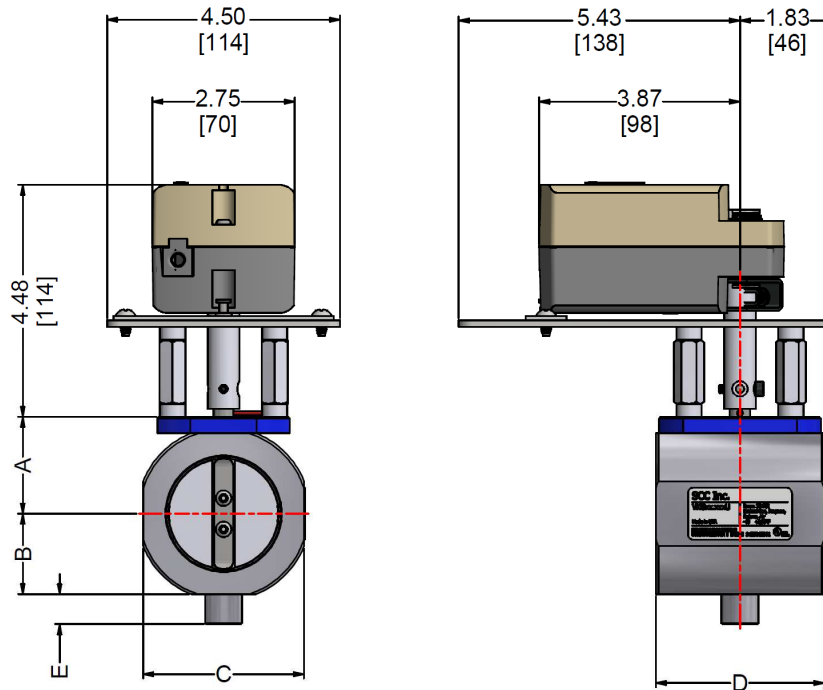

Table 4: VAGQD... Dimensions

Assembly Part Number Suffix	A	B	C	D	E
050H	1.35 [34]	1.12 [29]	2.08 [53]	3.25 [83]	0.21 [5]
075	1.35 [34]	1.04 [26]	2.08 [53]	3.25 [83]	0.58 [15]
100	1.35 [34]	1.04 [26]	2.08 [53]	3.25 [83]	0.58 [15]
125	1.53 [39]	1.22 [31]	2.44 [62]	3.25 [83]	0.58 [15]
150	1.63 [41]	1.31 [33]	2.63 [67]	3.25 [83]	0.58 [15]
200	1.87 [47]	1.55 [39]	3.11 [79]	3.25 [83]	0.58 [15]
250	2.18 [55]	1.87 [47]	3.74 [95]	4.38 [111]	0.58 [15]
300	2.44 [62]	2.13 [54]	4.26 [108]	4.38 [111]	0.58 [15]
400	2.96 [75]	2.64 [67]	5.28 [134]	5.00 [127]	0.58 [15]

Information in this publication is based on current specifications. The company reserves the right to make changes in specifications and models as design improvements are introduced. Product or company names mentioned herein may be the trademarks of their respective owners. © 2022 SCC Inc.