

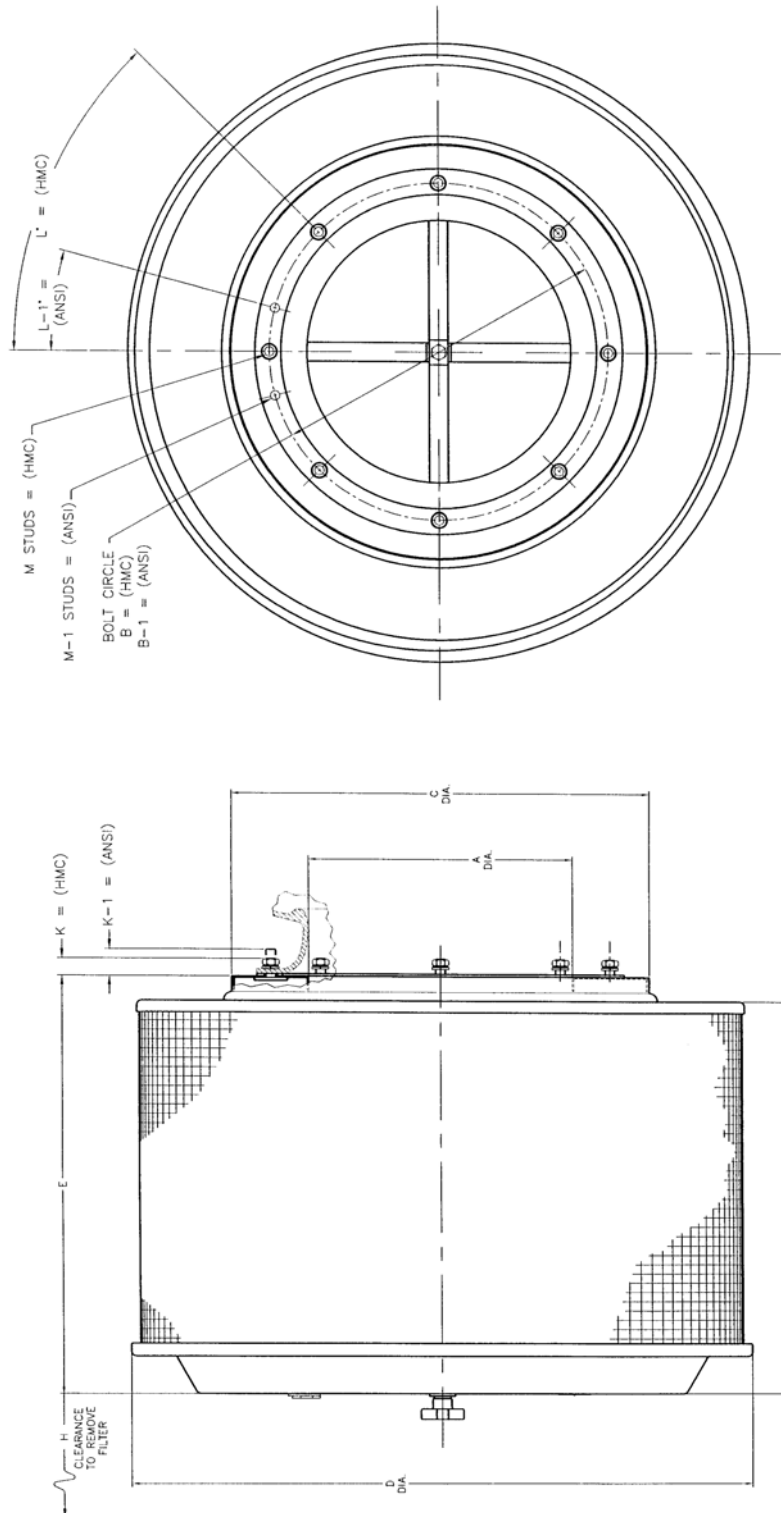

TBFS TURBO BLOWER FILTER SILENCER

**FILTERS
FBI1008 – FBI1018**



HMC = DIMENSIONS GIVEN ARE FOR THE "HAUCK MFG CO." BLOWER INLET FLANGE (e.g. FBI1000-HMC). ANSI = CLASS 125 FLANGE CONNECTION, WITH STUD SIZE SHOWN, IS AVAILABLE WHERE APPLICABLE (e.g. FBI1000-ANSI). COMPLETE MODEL NUMBER MUST BE SPECIFIED ON ORDER.

MODEL	A	B	B-1	C	D	E	H	J	K	K-1	L	L-1	M	M-1
FBI1008-	10	3/4	11	3/4	16	1/8	24	9	5	1/2	45	22	1/2	(8) 1/2-13 UNC (8) 1/2-13 UNC
FBI1010-	10	13	1/4	14	1/4	18	1/8	26	11	7	1/2	10	15	(8) 1/2-13 UNC (12) 1/2-13 UNC
FBI1012-	12	16	1/4	17	20	1/8	30	11	7	1/2	10	15	15	(8) 1/2-13 UNC (12) 1/2-13 UNC
FBI1112-	12	16	1/4	17	20	1/8	30	16	12	1/2	15	15	15	(8) 1/2-13 UNC (12) 1/2-13 UNC
FBI1014-	14	18	3/4	22	1/8	33	22	18	1/2	21	45	15	15	(8) 1/2-13 UNC (12) 1/2-13 UNC
FBI1018-	18	23	1/8	22	3/4	30	1/8	47	38	1/2	36	11	1/4	(10) 3/4-10 UNC (16) 3/4-10 UNC

X2303
(NOT TO SCALE)

(OVER)

In accordance with Hauck's commitment to Total Quality Improvement, Hauck reserves the right to change the specifications of products without prior notice.

FILTER SILENCERS FSB3008 – FSB3014

TBFS TURBO BLOWER FILTER SILENCER

DIMENSIONS

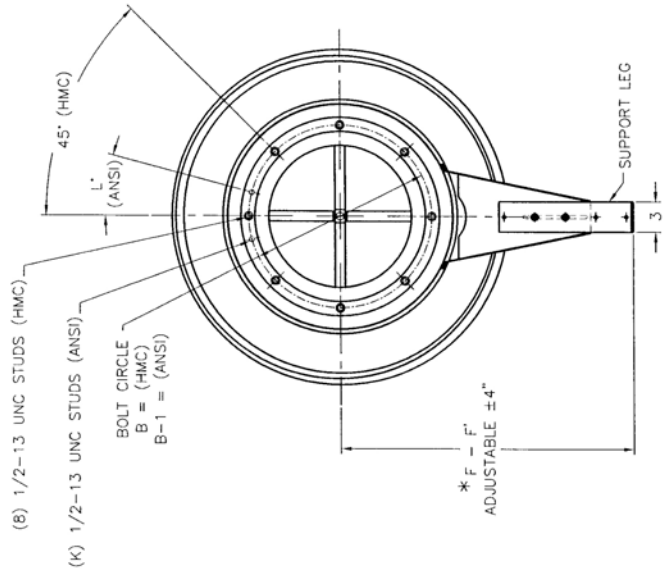

HMC = DIMENSIONS GIVEN ARE FOR THE "HAUCK MFG CO." BLOWER INLET FLANGE (#0 FSB3000-HMC). ANSI = CLASS 125 FLANGE CONNECTION, WITH STUD SIZE SHOWN IS AVAILABLE WHERE APPLICABLE (e.g. FSB3000-ANSI). COMPLETE MODEL NUMBER MUST BE SPECIFIED ON ORDER.
* F' DIMENSION IS APPLICABLE TO MODELS FSB3008-1-, 3010-1-, 3112-1-, 3212-1- ONLY.

X2299
(NOT TO SCALE)

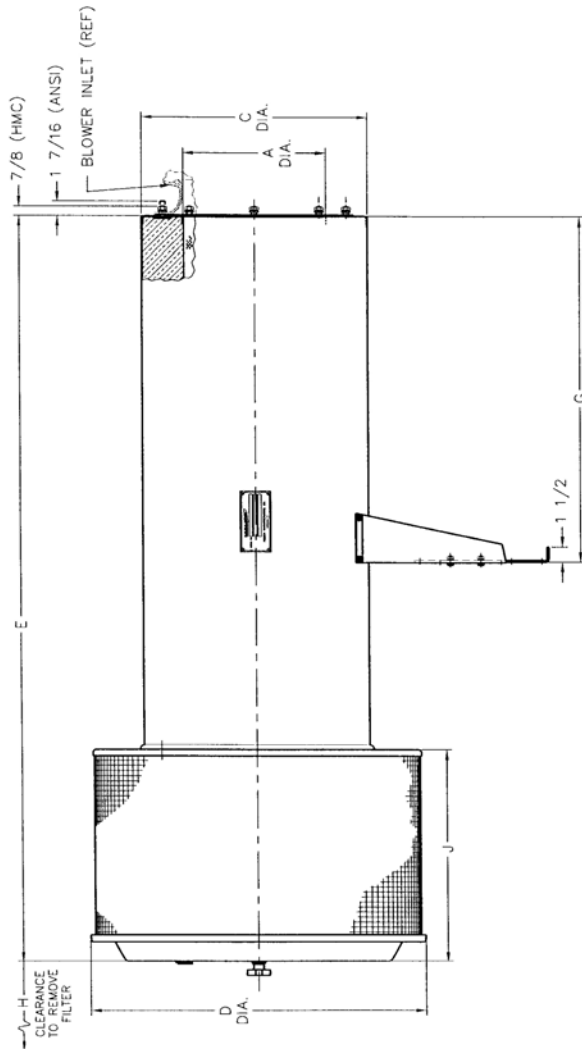

MODEL	A	B	B-1	C	D	E	F	F'	G	H	J	K	L
FSB3008-	8	10 3/4	11 3/4	16 1/8	24	26 1/4	25 3/4	30 3/4	14	5 1/2	8	8	22 1/2"
FSB3010-	10	13 1/4	14 1/4	18 1/8	26	36 3/4	26 3/4	31 3/4	19	7 1/2	10	12	15"
FSB3012-	12	16 1/4	17	20 1/8	30	47 1/4	27 3/4	32 3/4	24	7 1/2	10	12	15"
FSB3112-	12	16 1/4	17	20 1/8	30	47 1/4	27 3/4	32 3/4	24	12 1/2	15	12	15"
FSB3212-	12	16 1/4	17	20 1/8	30	61 1/4	27 3/4	32 3/4	31	12 1/2	15	12	15"
FSB3014-	14	18	18 3/4	22 1/8	33	69 3/4	28 3/4	34	18 1/2	21	21	12	15"



TBFS TURBO BLOWER FILTER SILENCER

**SILENCERS
SBI2008 – SBI2014**

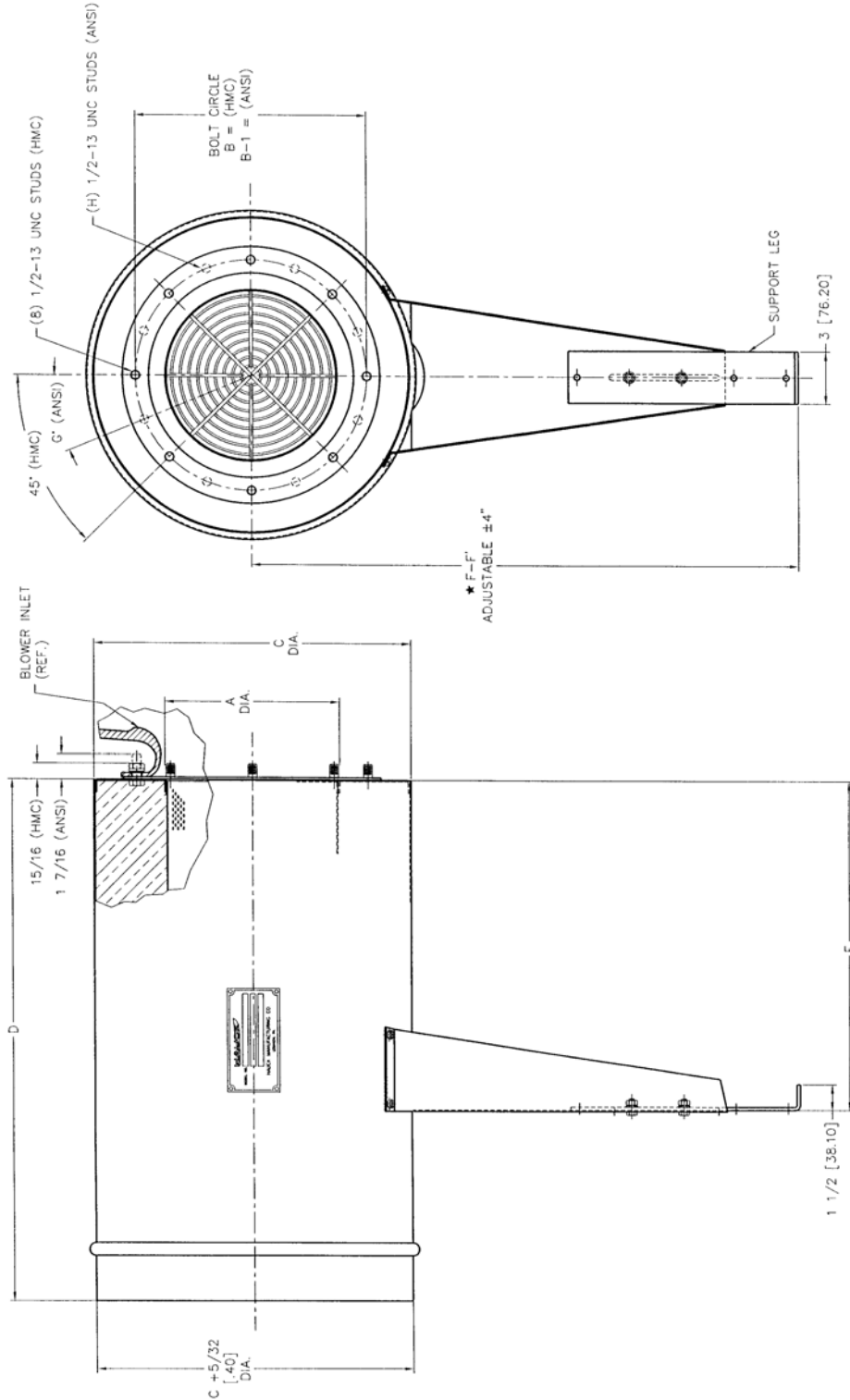

NOTE: DIMENSIONS GIVEN ARE FOR THE "HAUCK MFG. CO." BLOWER INLET FLANGE (e.g. SBI 2000-HMC).
 HMC = ANSI 125 CLASS FLANGE CONNECTION, WITH STUD SIZE SHOWN, IS AVAILABLE WHERE APPLICABLE.
 ANSI = (e.g. SBI 2000-ANSI). COMPLETE MODEL NUMBER MUST BE SPECIFIED ON ORDER.
 * = F' DIMENSION IS APPLICABLE TO MODELS SBI 2008-1-, 2010-1-, 2112-1-, 2212-1- ONLY

MODEL	A	B	B-1	C	D	E	F	F'	G	H
SBI2008--	8	10 3/4	11 3/4	16 1/8	20	14	25 3/4	30 3/4	22 1/2	8
SBI2010--	10	13 1/4	14 1/4	18 1/8	30	19	26 3/4	31 3/4	15*	12
SBI2012--	12	16 1/4	17	20 1/8	40	24	27 3/4		15*	12
SBI2112--	12	16 1/4	17	20 1/8	40	24	27 3/4	32 3/4	15*	12
SBI2212--	12	16 1/4	17	20 1/8	54	31	27 3/4	32 3/4	15*	12
SBI2014--	14	18	18 3/4	22 1/8	60	34	28 3/4		15*	12

X2302
(NOT TO SCALE)

(OVER)

In accordance with Hauck's commitment to Total Quality Improvement, Hauck reserves the right to change the specifications of products without prior notice.

SILENCERS SBI2018

TBFS TURBO BLOWER FILTER SILENCER

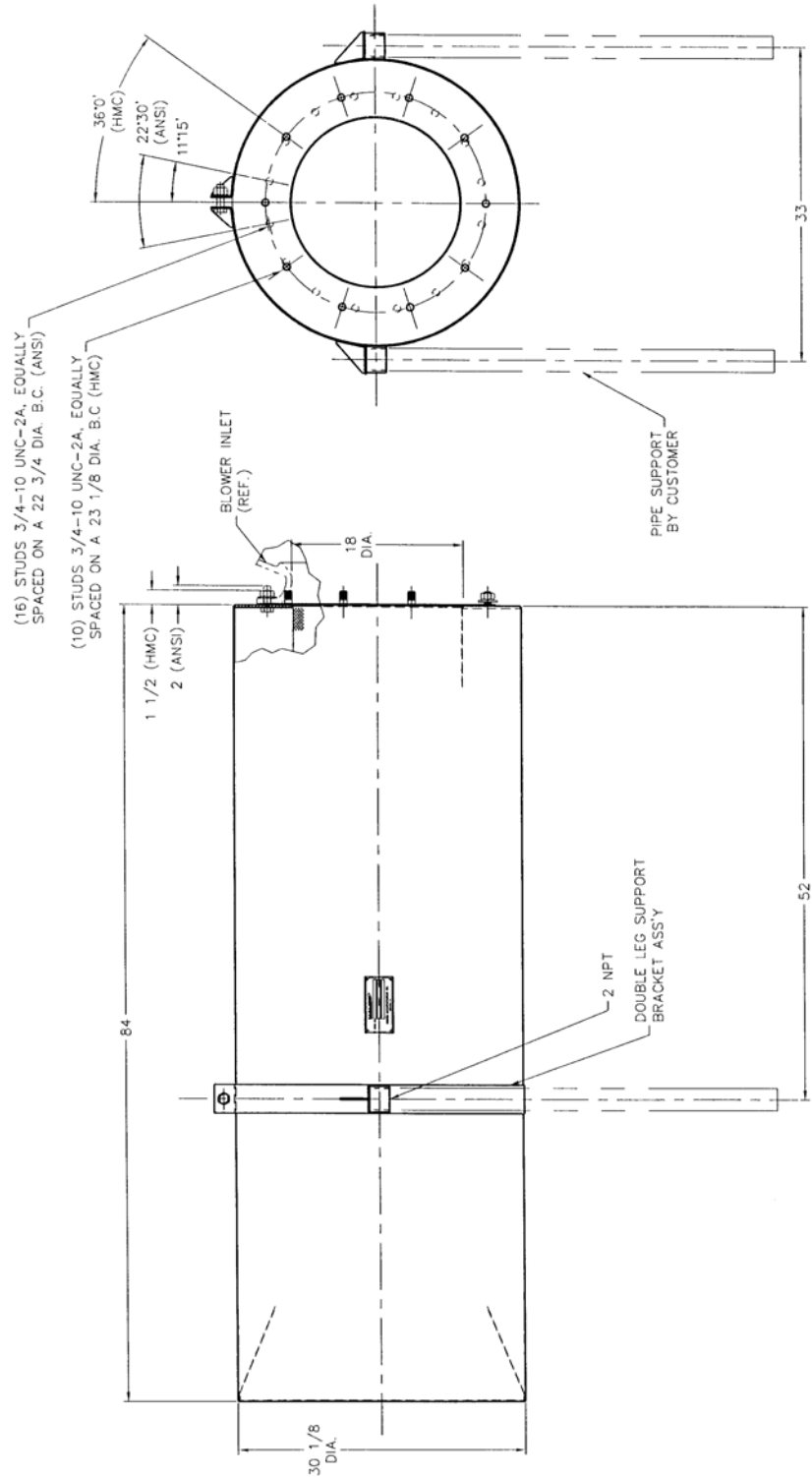

NOTE: DIMENSIONS GIVEN ARE FOR THE "HAUCK MFG. CO." BLOWER INLET FLANGE (e.g. SBI 2018-HMC). ANSI = ANSI CLASS 125 FLANGE CONNECTION. WITH STUD SIZE SHOWN, IS AVAILABLE WHERE APPLICABLE (e.g. SBI 2018-ANSI). COMPLETE MODEL NUMBER MUST BE SPECIFIED ON ORDER.

X3028
(NOT TO SCALE)



SUPPLEMENTAL DATA

INSERTION LOSS – dB

Insertion Loss is the reduction in sound power (or the sound energy lost) between the accessory inlet and the accessory outlet. This value is normally expressed in dB. The insertion losses given in Table 1 are actual values obtained through laboratory tests. These values are used with the other parameters given on the back of this page (Blower Noise Calculation) to calculate the blower's dB(A) noise level after the addition of a Hauck accessory. Complete instructions on how to make this calculation are given in Hauck Application Sheet GJ52.

HAUCK FILTER

MODEL	OCTAVE BAND (HZ)							
	63	125	250	500	1000	2000	4000	8000
FBI 1008	-	-	1.5	4.5	3.0	5.5	7.0	5.5
FBI 1010	-	-	1.5	0.0	3.5	8.5	12.0	8.0
FBI 1012	-	-	2.0	3.0	2.5	9.5	13.5	8.5
FBI 1112	-	-	3.0	0.5	4.5	9.0	15.0	10.5
FBI 1014	-	-	2.5	0.0	7.0	10.0	14.0	9.5
FBI 1018	-	-	2.0	1.5	4.0	8.5	12.5	8.5

HAUCK SILENCER

MODEL	OCTAVE BAND (HZ)							
	63	125	250	500	1000	2000	4000	8000
SBI 2008	2.0	6.0	12.0	14.0	22.0	22.0	17.0	14.0
SBI 2010	4.0	9.0	13.5	19.0	29.0	22.5	15.0	10.0
SBI 2012	4.5	10.5	15.0	20.5	33.5	20.5	15.0	13.0
SBI 2112	4.5	10.5	15.0	20.5	33.5	20.5	15.0	13.0
SBI 2212	7.0	13.5	20.0	30.5	41.0	25.5	15.5	14.5
SBI 2014	7.0	12.5	18.0	32.0	37.5	20.0	14.0	13.0
SBI 2018	12.0	18.0	25.0	37.5	32.5	22.5	16.0	10.0

HAUCK FILTER-SILENCER

MODEL	OCTAVE BAND (HZ)							
	63	125	250	500	1000	2000	4000	8000
FSB 3008	2.0	6.0	13.5	18.5	25.0	27.5	24.0	19.5
FSB 3010	4.0	9.0	14.5	18.5	32.5	31.0	27.0	18.0
FSB 3012	4.5	10.5	17.0	24.0	36.0	30.0	28.0	21.5
FSB 3112	4.5	10.5	17.0	24.0	36.0	30.0	28.0	21.5
FSB 3212	7.0	13.5	23.0	31.0	45.5	34.5	30.5	25.0
FSB 3014	7.0	12.5	20.0	31.0	44.5	30.0	28.0	22.5
FSB 3018	12.0	18.0	27.0	39.0	36.5	31.0	28.5	18.5

Table 1. Insertion Loss Data

In accordance with Hauck's commitment to Total Quality Improvement, Hauck reserves the right to change the specifications of products without prior notice.

SELECTION

The proper selection of the accessory best suited to your application has been simplified by the use of selection tables. If the accessory is to be used with a Hauck Turbo Blower, use TBFS-4.1 for direct drive models and TBFS-4.2 for belt drive models. The appropriate filter, silencer, and filter-silencer model numbers are listed directly across from the blower model number. If the accessory is to be used with a blower not engineered by Hauck, use Table 2. Note that the proper selection of a unit for a 12" blower inlet will depend on the volume of air to be handled.

INLET DIAMETER		MAXIMUM AIR FLOW		RECOMMENDED FILTER	RECOMMENDED SILENCER	RECOMMENDED FILTER-SILENCER
(inches)	(mm)	(scfm)	(nm ³ /min)			
8	200	1,740	46.6	FBI 1008	SBI 2008	FSB 3008
10	250	2,650	71.0	FBI 1010	SBI 2010	FSB 3010
12	300	<3,060	<82.0	FBI 1012	SBI 2012	FSB 3012
12	300	3,060 - 4,000	82.0 - 107	FBI 1112	SBI 2112	FSB 3112
12	300	4,000 - 5,400	107 - 145	FBI 1112	SBI 2212	FSB 3212
14	350	9,000	241	FBI 1014	SBI 2014	FSB 3014
18	450	---	---	FBI 1018	SBI 2018	FSB 3018

*Maximum flow data apply to filter only.

Table 2. Recommended Filter/Silencer for Non-Hauck Blowers

BLOWER NOISE CALCULATION

The noise levels associated with your blower depend on many factors. An accurate calculation of the level to be expected after the addition of a Hauck silencer requires that the following be taken into account.

1. The sound power level (PWL) of the unsilenced blower by octave bands.
2. The inlet directional gain (DG) of the unsilenced blower by octave bands.
3. The insertion loss (IL) by octave for the accessory used.
4. The distance from the point of sound measurement (point "A") to the blower air inlet and the motor.
5. The motor sound power level (PWLM) by octave bands.

This data can be used in conjunction with a worksheet designed to help you determine the dB(A) noise level for any conventional blower equipped with a Hauck silencer. The worksheet and supportive data, as well as complete instructions for their use, are available on request (ask for Hauck Application Sheet GJ52). For your convenience, these calculations have been carried out for accessories mounted on Hauck direct drive blowers. TBFS-4.1 gives the dB(A) level for each unsilenced Hauck direct drive blower and the level to be expected after the addition of a Hauck filter, silencer, or filter-silencer.

PRESSURE DROP

The pressure drop imposed on the blower by the addition of the accessory will depend on the accessory used and the volume of air handled. Complete pressure drop data on each accessory, at various flow rates, is presented in the graphs on TBFS-4.3. These graphs allow you to determine the actual pressure drop to be expected when using a Hauck filter, silencer, or filter-silencer.



RECOMMENDED FILTER/SILENCER HAUCK DIRECT DRIVE BLOWER

Table 3 lists the appropriate filter, silencer, and filter-silencer to be used with each Hauck direct drive blower regardless of the blower motor configuration used. The dB(A) noise levels shown, however, are for units equipped with a totally enclosed motor. They do not apply to units equipped with an open motor. The values applicable to blowers with open motors will vary and must be calculated as described in Hauck Application Sheet GJ 52. All of the "With Accessory" dB(A) noise levels listed in Table 3 are calculated levels for a point five feet from the ground and five feet from the inlet flange for Hauck blowers equipped with TEFC motors operating under full load conditions in a free field environment. (For 50 Hertz-Metric turbo blower filter, silencer, and filter silencer recommendations. see Hauck Data Sheet GB 140.)

Blower Model Number	Without Accessory	With Accessory					
	dB(A) Level	Filter Model Number	dB(A) Level	Silencer Model Number	dB(A) Level	Filter-Silencer Model Number	dB(A) Level
TBA 12-1 1/2-T	79.5	FBI 1008	78.5	SBI 2008	77.5	FSB 3008	77.5
TBA 12-2-T	80.5	FBI 1008	80	SBI 2008	78	FSB 3008	77.5
TBA 12-3-T	80.5	FBI 1008	80	SBI 2008	78	FSB 3008	77.5
TBA 12-5-T	84	FBI 1010	83	SBI 2010	78	FSB 3010	78
TBA 12-7 1/2 -T	93.5	FBI 1012	89	SBI 2012	89	FSB 3012	78.5
TBA 12-10-T	93.5	FBI 1112	90	SBI 2112	80.5	FSB 3112	78.5
TBA 12-15-T	100.5	FBI 1014	97	SBI 2014	86	FSB 3014	84
TBA 12-20-T	-	FBI 1014	-	SBI 2014	-	FSB 3014	-
TBA 12-25-T	-	FBI 1014	-	SBI 2014	-	FSB 3014	-
TBA 12-30-T	-	FBI 1014	-	SBI 2014	-	FSB 3014	-
TBA 16-3-T	82	FBI 1008	80	SBI 2008	77.5	FSB 3008	77.5
TBA 16-5-T	87.5	FBI 1008	84	SBI 2008	78	FSB 3008	77.5
TBA 16-7 1/2-T	89.5	FBI 1010	87	SBI 2010	79.5	FSB 3010	78.5
TBA 16-10-T	89.5	FBI 1010	87	SBI 2010	79.5	FSB 3010	78.5
TBA 16-15-T	94	FBI 1112	92	SBI 2112	85	FSB 3112	84
TBA 16-20-T	94	FBI 1112	92	SBI 2212	84.5	FSB 3212	84
TBA 16-25-T	103	FBI 1014	98.5	SBI 2014	87.5	FSB 3014	83.5
TAB 16-30-T	103	FBI 1014	98.5	SBI 2014	87.5	FSB 3014	83.5
TBA 16-40-T	104.5	FBI 1014	100.5	SBI 2014	89.5	FSB 3014	85.5
TBA 20-5-T	88.5	FBI 1010	85.5	SBI 2010	78.5	FSB 3010	78
TBA 20-7 1/2-T	92	FBI 1012	88	SBI 2012	79.5	FSB 3012	78
TBA 20-10-T	92	FBI 1012	88	SBI 2012	79.5	FSB 3012	78
TBA 20-15-T	96	FBI 1112	92.5	SBI 2112	85.5	FSB 3112	84
TBA 20-20-T	96	FBI 1112	93	SBI 2112	85	FSB 3112	84
TBA 20-25-T	96	FBI 1112	93	SBI 2212	84	FSB 3212	83
TBA 20-30-T	100.5	FBI 1014	96.5	SBI 2014	84	FSB 3014	84
TBA 20-40-T	100.5	FBI 1014	96.5	SBI 2014	87	FSB 3014	85
TBA 20-50-T	-	FBI 1014	-	SBI 2014	87.5	FSB 3014	-
TBA 20-60-T	-	FBI 1014	-	SBI 2014	-	FSB 3014	-
TBA 24-5-T	92	FBI 1010	88	SBI 2010	-	FSB 3010	78.5
TBA 24-7 1/2-T	92	FBI 1010	88	SBI 2010	79.5	FSB 3010	78.5
TBA 24-10-T	98.5	FBI 1012	94.5	SBI 2012	79.5	FSB 3012	79
TBA 24-15-T	98.5	FBI 1012	94.5	SBI 2012	82.5	FSB 3012	84
TBA 24-20-T	98.5	FBI 1112	94.5	SBI 2112	85.5	FSB 3112	84.5
TBA 24-25-T	98.5	FBI 1112	94.5	SBI 2112	86	FSB 3112	83.5
TBA 24-30-T	101	FBI 1112	97	SBI 2212	85.5	FSB 3212	83
TBA 24-40-T	101	FBI 1112	97	SBI 2212	86	FSB 3212	84.5
TBA 24-50-T	100.5	FBI 1014	97	SBI 2014	88.5	FSB 3014	85
TBA 24-60-T	100.5	FBI 1014	97	SBI 2014	89	FSB 3014	86

Table 3. Recommended Filter/Silencer for Hauck Direct Drive Blowers

In accordance with Hauck's commitment to Total Quality Improvement, Hauck reserves the right to change the specifications of products without prior notice.

Blower Model Number	Filter Model Number	Silencer Model Number	Filter-Silencer Model Number
TBA 32-7 1/2	FBI 1008	SBI 2008	FSB 3008
TBA 32-10	FBI 1008	SBI 2008	FSB 3008
TBA 32-15	FBI 1008	SBI 2008	FSB 3008
TBA 32-20	FBI 1008	SBI 2008	FSB 3008
TBA 32-25 *	FBI 1010	SBI 2010	FSB 3010
TBA 32-30 *	FBI 1010	SBI 2010	FSB 3010
TBA 32-40 *	FBI 1112	SBI 2112	FSB 3112
TBA 32-50 *	FBI 1112	SBI 2212	FSB 3212
TBA 32-60 *	FBI 1112	SBI 2212	FSB 3212
TBA 32-75 *	FBI 1014	SBI 2014	FSB 3014
TBA 32-100	FBI 1018	SBI 2018	FSB 3018
TBA 32-125	FBI 1018	SBI 2018	FSB 3018
TBA 32-150	FBI 1018	SBI 2018	FSB 3018
TBA 36-10	FBI 1008	SBI 2008	FSB 3008
TBA 36-15	FBI 1008	SBI 2008	FSB 3008
TBA 36-20	FBI 1008	SBI 2008	FSB 3008
TBA 36-25	FBI 1008	SBI 2008	FSB 3008
TBA 36-30 *	FBI 1010	SBI 2010	FSB 3010
TBA 36-40	FBI 1010	SBI 2010	FSB 3010
TBA 36-50 *	FBI 1112	SBI 2212	FSB 3212
TBA 36-60 *	FBI 1112	SBI 2212	FSB 3212
TBA 36-75 *	FBI 1014	SBI 2014	FSB 3014
TBA 36-100 *	FBI 1014	SBI 2014	FSB 3014
TBA 36-125	FBI 1018	SBI 2018	FSB 3018
TBA 36-150	FBI 1018	SBI 2018	FSB 3018

Table 3. (Continued)

Notes:

1. Size is based on maximum flow through filter criteria of Table 2. Recommended Filter/Silencer for Non-Hauck Blower.
2. Size is based on flow through filter at maximum pressure drop of 1.5"w.c (373 Pa).
3. Sizes designated with an asterisk '*' indicate an oversized filter/silencer diameter with respect to the blower inlet diameter size. A transition assembly is required; consult Hauck.



**RECOMMENDED FILTER/SILENCER
HAUCK BELT DRIVE BLOWER**

Table 4 lists the appropriate filter, silencer, and filter-silencer to be used with each Hauck belt drive blower regardless of the motor configuration used. The reduction in dB(A) noise level obtained after the addition of a Hauck accessory will depend on the motor speed and the blower volume, pressure and impeller speed. Since these values vary, not only between models, but also between different configurations of the same model, they have been omitted from Table 4. Complete instructions on how to calculate the blower's noise level after the installation of a Hauck accessory are in Hauck Application Sheet GJ52.

Blower Model Number	Filter Model Number	Silencer Model Number	Filter-Silencer Model Number
TBAB 010-010-A	FBI 1008	SBI 2008	FSB 3008
TBAB 010-080-A	FBI 1008	SBI 2008	FSB 3008
TBAB 020-030-A	FBI 1008	SBI 2008	FSB 3008
TBAB 020-090-A	FBI 1008	SBI 2008	FSB 3008
TBAB 030-040-A	FBI 1010	SBI 2010	FSB 3010
TBAB 030-110-B	FBI 1010	SBI 2010	FSB 3010
TBAB 040-060-B	FBI 1012	SBI 2012	FSB 3012
TBAB 040-130-E	FBI 1012	SBI 2012	FSB 3012
TBAB 050-070-C	FBI 1014	SBI 2014	FSB 3014
TBAB 050-150-E	FBI 1014	SBI 2014	FSB 3014
TBAB 060-250-B	FBI 1010	SBI 2010	FSB 3010
TBAB 061-251-E	FBI 1010	SBI 2010	FSB 3010
TBAB 070-070-C	FBI 1012	SBI 2012	FSB 3012
TBAB 071-271-E	FBI 1112	SBI 2112	FSB 3112
TBAB 080-290-E	FBI 1112	SBI 2112	FSB 3112
TBAB 081-291-E	FBI 1112	SBI 2112	FSB 3112
TBAB 081-291-F	FBI 1112	SBI 2112	FSB 3112
TBAB 090-310-E	FBI 1112	SBI 2112	FSB 3112
TBAB 090-310-F	FBI 1112	SBI 2112	FSB 3112
TBAB 091-311-G	FBI 1112	SBI 2112	FSB 3112
TBAB 091-311-J	FBI 1014	SBI 2014	FSB 3014
TBAB 100-330-G	FBI 1014	SBI 2014	FSB 3014
TBAB 100-330-H	FBI 1014	SBI 2014	FSB 3014
TBAB 100-330-J	FBI 1014	SBI 2014	FSB 3014
TBAB 101-321-J	FBI 1014	SBI 2014	FSB 3014

Table 4. Recommended Filter/Silencer for Hauck Belt Drive Blowers

In accordance with Hauck's commitment to Total Quality Improvement, Hauck reserves the right to change the specifications of products without prior notice.

This page left intentionally blank.